

VSC-2000

Installation Manual

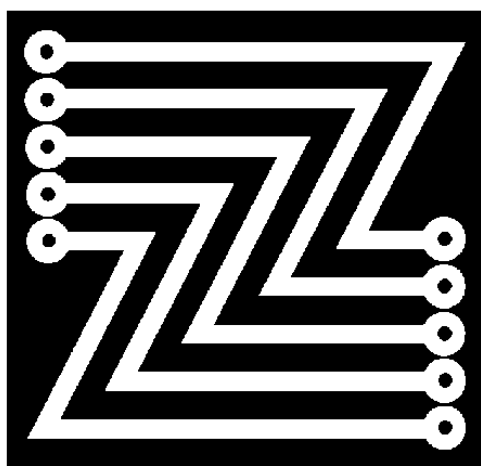

ZENER

ZENER TECHNOLOGY AND QUALITY ASSURANCE

Since 1978 Zener Electric has supplied many thousands of AC drives to Australian Industries. These drives have been installed into numerous applications resulting in a wealth of in house experience.

The Zener VSC 2000 AC motor variable speed controller is the culmination of this expertise, modern technology and industrial application requirements.

The Zener Quality Assurance program ensures that every VSC 2000 manufactured has proven to operate correctly in the production test bay before dispatch.

VSC 2000 PRODUCT WARRANTY

Zener Electric warranty the VSC 2000 against defective workmanship and materials for a period of 24 months from the date of dispatch. Such defects will be rectified free of charge for both labour and material, at Zener Electric's premises subject to:

1. Zener Electric's customer raising an order upon Zener for service and/or repairs, subject to a warranty claim. The order is to state particulars of the model and serial number, the date of original purchase and invoice/delivery docket number.
2. All damage resulting from incorrect installation or use other than in accordance with the instruction manuals issued by Zener Electric is excluded from this warranty.
3. The Warranty being rendered invalid if the product is misused or if any unauthorised alteration, modification or substitution of any part of the product be made or the serial number of the product is defaced or altered.
4. The cost of transportation (both ways) is to be met by the owner if it is necessary to return the product, or any part of it, to Zener Electric's premises.
5. A charge being accepted by the owner for traveling time and expenses incurred in connection with warranty service at the user's site as requested by the owner.
6. If the product was not purchased from Zener Electric directly, then a warranty claim must be lodged with the original supplier in the first instance. Repairs will not be effected by Zener Electric unless approved by the original supplier.
7. Goods not of our own manufacture incorporated in our supply or merchanted by us, carry their maker's warranty only.
8. Goods returned for claim under warranty will be accepted on the condition that should the claim be rejected then all costs, including inspection, will be charged to the customer's account.
9. Zener Electric is not liable for any consequential loss.

SAFETY

Your VSC 2000 must be applied, installed and operated in a safe manner. It is the responsibility of the user to ensure compliance with all regulations and practices covering the installation and wiring of your VSC 2000. The Installation Manual section should be completely read and understood before attempting to connect or operate the VSC 2000. Only skilled personnel should install this equipment.

**THE CONTENTS OF THIS MANUAL ARE SUBJECT TO CHANGE
WITHOUT NOTICE**

The VSC-2000

- A promise of performance and flexibility that delivers

Common Customer interface from 7 through to 160kw for simplified operation

IGBT's for silent operation, compact size as well as high reliability and performance

Solid State electronics for high reliability, compact size and vibration resistance

Touch sensitive programmable, easy to read, back-lit LCD screen

IP55 (NEMA12) enclosure. Metal construction for harsh industrial environments

The Comprehensive control station may be removed and remote mounted up to 100m from controller

Comprehensive display to provide indication of a range of variables simultaneously

UL listing for Selected Chassis and undergoing tests for CE & CSA

Keypad pushbuttons for motor control and potentiometer for ease of manual speed control



- With a host of high-performance software features

- High speed digital microprocessor with in-built PWM output waveform synthesis
- Mounting Points provided for through panel mounting of heat producing section to the outside of cabinets.
- RS-485 serial communications port for control and computer link.
- 2 Programmable analog inputs
- Up to 12 programmable digital inputs
- A DC bus choke for reduced harmonics, improved power factor and improved immunity to mains transients
- Up to 4 programmable digital outputs with optional Extended Features Board
- Quick disconnect terminal strip, isolated from ground and power
- 2 programmable relay outputs
- Optional built-in dynamic braking control and power switch

NEW FEATURES !

Settable digital output conditions such as fan load warning, over speed, at speed etc. Phase imbalance trip, power fail trip, phase failure trip and more !!

- ▶ The VSC2000 gives you a range of standard built-in features that puts you in control of a wide variety of applications.
- ▶ Programmable carrier frequency from 2kHz to 16kHz optimizes energy efficiency and audible motor noise.
- ▶ Choice of three control terminal configurations; Industrial, HVAC and Enhanced terminals. HVAC terminals make for easy building management system integration.
- ▶ Automatic slip-compensation for maintaining motor speed under varying loads.
- ▶ Thermal protection and output current limit are settable for critical motor sizing applications.
- ▶ PID controller and tacho feedback input for closed loop control.
- ▶ Four skip speed lockout frequency bands to avoid load and resonance during ramp up or ramp down.
- ▶ DC injection braking and optional dynamic braking for rapid load stopping
- ▶ Two acceleration and deceleration ramps adjustable from 0.5 seconds to 10 minutes.
- ▶ Customer selectable Auto Restart with programmable delay up to 20 minutes
- ▶ Run log and trip log which records the last 10 trips events.
- ▶ Remote interrogation and programming of features via RS485 serial communications.

VSC 2000 Installation Manual

Table of Contents

Section	Page
Scope, Conventions, Receiving	1
General Specifications	2
Small Chassis Mechanical Installation Diagram	4
Medium Chassis Mechanical Installation Diagram	5
Large Chassis Mechanical Installation Diagram	6
Electrical Installation Diagram	7
Terminal Configurations	8
Control Wiring Diagrams	10
Start-Up Procedure	13
Adjustment Procedure	13
Setups	15
Monitoring Drive Output	17
Restoring Factory Settings	17
Messages	18
Trouble Shooting Guide	19
Your Set-up Notes	21

Scope

This document is intended for use as a guide to install and safely power-up the VSC 2000. It contains only essential information to complete this task. This manual should be read in conjunction with the **VSC 2000 User's Manual**, which contains information detailing programming and operation instructions. All recommendations given should be followed and in case of uncertainty contact Zener Electric Sydney who can provide a written recommendation on request.

Conventions

Words that are capitalized and in italics, such as *COMPLETE SETUP*, refer to menu items that can be accessed via the touch screen on the Comprehensive Control Station or CCS. Words in **Bold** refer to sections within this document.

Receiving

Inspect the VSC 2000 for shipping damage. If any damage is found, report it to the carrier immediately. Access the inside of the controller and visually check for any damage.

DO NOT ATTEMPT TO OPERATE THE VSC 2000 IF ANY OBVIOUS DAMAGE EXISTS.

After the initial inspection, the VSC 2000 can be re-packed and stored in a clean dry location until it is ready to be used again. DO NOT store this equipment in any area where the ambient temperature will rise above 70°C (158°F) or drop below -20° (-4°F). DO NOT store this equipment in areas of high condensation or corrosive atmosphere. Proper storage is necessary to ensure satisfactory controller start-up and performance.

VSC 2000 General Specifications

Input Supply Voltage	
VSC 2000 A Series	208Vac (-15%) to 240Vac (+10%)
VSC 2000 G Series	346Vac (-15%) to 480Vac (+10%)
VSC 2000 J Series	440Vac (-15%) to 600Vac (+10%)
Input Frequency Range	
48Hz to 62Hz	
Output Motor Voltage	
VSC 2000 A Series	0 to 240Vac
VSC 2000 G Series	0 to 480Vac
VSC 2000 J Series	0 to 600Vac Output voltage cannot exceed input voltage.
Maximum Output Current	
1.1 x Continuous Output Current -see drive ratings VSC 2000 Electrical Installation Diagram	
Output Frequency	
0Hz to 200Hz	
Frequency Resolution	
0.1% of selected maximum with CCS pot.	
Frequency Linearity	
0.2% of selected maximum frequency.	
Enclosure Rating	
IP55 (NEMA 12) Note: IP55 does not require air filters	
Chassis Colour Number	
APO Dulux Powder Coat	
Environmental Rating	
Storage Temperature -20°C(-4°F) to +70°C(158°F)	
Operating Temperature 0°C(32°F) to 50°C(122°F)* *Average over a 24 hour period ≤ 45°C(113°F).	
Relative Humidity 5% to 95% non-condensing	
Local Controls	
Function	Name
Forward	FWD
Reverse	REV
Stop	STOP
Remote	AUTO
Local	MAN
Speed Potentiometer	SPEED
Touch Screen	
Activation force	60 to 120g (2 to 4oz)
Lifetime	10 million cycles

Terminal Strip (see page 10)	
User Serial Port EIA Standard RS-485	
Analog Inputs Two analog inputs IN 1+/IN 1- and IN 2+/IN 2-. Both inputs are independently configurable as either: 0 to 5Vdc (Rin > 100 kOhms) 1 to 5Vdc (Rin > 100 kOhms) 0 to 10Vdc (Rin > 100 kOhms) 4 to 20mAdc (Rin = 250 Ohms) 0 to 20mAdc (Rin = 250 Ohms) Input signals may be differential or ground referenced. Common mode range for IN 1+, IN 1-, IN 2+ and IN 2- is ±26 V with respect to ANA COM or ground. +5V (terminal 10) max. current rating is 33mA,sourced.	
Analog Outputs Two differential outputs OUT 1 and OUT 2* independently configurable as either: 0 to 5Vdc 1 to 5Vdc 0 to 10Vdc 4 to 20mAdc 0 to 20mAdc Signal source can be speed, load or bipolar load. (See also PID Analog Outputs) Galvanically isolated to ±42Vdc. Maximum output current rating 20mA. OUT 2 is available on the Extended Features Board.	
Digital Input and Outputs Inputs and outputs are opto-isolated. Common mode range is ±42Vdc with respect to ground. +24V Supply (terminals 48, 49 & 84) Maximum current from terminals 48, 49 & 84 combined = 400 mA. Digital Inputs (terminals 40 to 47 and 80 to 83) Digital Inputs A to H and J to M logic levels Input Logic High: 12Vdc to 30Vdc Input Logic Low: -6Vdc to 2.2Vdc Digital Outputs (terminals 80, 81, 82 & 83) Maximum current per output = 300mAdc Digital Outputs are active high (source current). Maximum current sourced from terminals 80, 81, 82 & 83 combined = 350mAdc.	
Digital Outputs J, K, L & M and relays RL 1, RL 2 indications:	
Zero Speed Run Signal Under Speed (user set speed) Over Speed (user set speed) At Speed Drive Enabled Forward Direction Reverse Direction On Off Proof	ESO Trip Manual PID Saturation PID Output Saturation PV Over Alarm Auto Restart Available Fan Load Warning Thermal trip I2t trip Over Temperature Trip
Relays RL 1 and RL 2 Contact Ratings cosΦ = 1.0 cosΦ = 0.4, L/R = 7ms 8A @ 250Vac 3.5A @ 250Vac 8A @ 30Vdc 3.5A @ 30Vdc	

VSC 2000 General Specifications

User Parameters	
Limits on all user parameters:	
Motor Voltages	
VSC 2000 A Series	208V to 240V
VSC 2000 G Series	346V to 480V
VSC 2000 J Series	440V to 600V
Nameplate Current	0.5 to 1.5 x drive rated current
Motor Frequency	40Hz to 200Hz
Nameplate Speed RPM	600 to 7000 rpm
Ramp 1 and Ramp 2	
Accel and Decel	0.5s to 600s
Accel S and Decel S	0.01 to 40
Current Limit	36 - 110% of drive rated current
Minimum Frequency	
Programmable minimum motor frequency 0 to Maximum Frequency - 5Hz	
Maximum Frequency	
Programmable maximum motor frequency 5Hz to 200Hz	
Preset Speeds	
6 programmable preset speeds Minimum to maximum frequency	
Skip Speeds	
4 programmable skip speeds	
Speed	0 to maximum frequency
Range	0 to maximum frequency
Speed Override/Essential Services	
Speed	Minimum to maximum frequency
Speed Source	
Internal (programmable)	Minimum to maximum frequency
External (default)	IN 2 (terminals 14, 15)
Slip Compensation	0 to 150% (of slip frequency)
Drive Stopping Modes	
	Coast to Stop
	Ramp to Stop
	DC Brake
DC Braking	
Brake Strength	0 to 100% of driveintermittent
Brake Duration	0 to 60s current rating

User Parameters (cont.)	
Auto Restart	
Number of restarts	2 to 15
Reset Time	1 to 20 minutes
Thermal Protection	
Devices	
	Thermistor - 3k3 nominal @ rated temperature.
	Microtherm/thermal switch/thermal overload.
I²t Protection	36 to 150% of entered motor nameplate current
Automatic Boost	0 to 150%
Audible Frequency	
	2.0kHz to 16.0kHz
	Selectable in 2kHz steps + Automatic Selection
	- optimised for silent operation with high efficiency at near full speed.
Power On Mode	Manual or Auto
Language	
	English
	Malay
	Spanish
	Swedish
The following features can be enabled/disabled:	
Reverse Direction	Motorized Pot
CCS in Auto	Phase FailureTrip
Thermal Trip	Power Failure Trip
I²t Protection	Imbalance Trip
Reverse Acting Input Signals	
Bipolar Input Signals	
Auto Restart	
Power Fail trip Reset	
Skip Speeds 1 to 4 (independently)	
Essential Services	
DC Braking	
Dynamic Braking	
Display	
Running Screen	
	Speed, speed reference
Temperature Display	
	Internal Ambient temperature (°C)
	Heatsink temperatures (°C)
Meter Readouts	
	Motor Current (A)
	Output Frequency (Hz)
	Terminal Power (kW)
	% load (%)
	Bus volts (V)

Above specifications are subject to change without notice.

VSC Small Chassis Mechanical Installation Diagrams

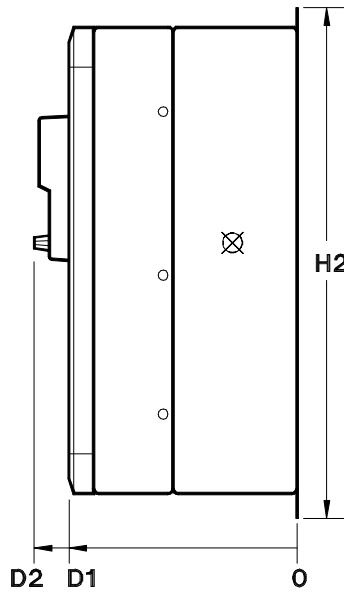
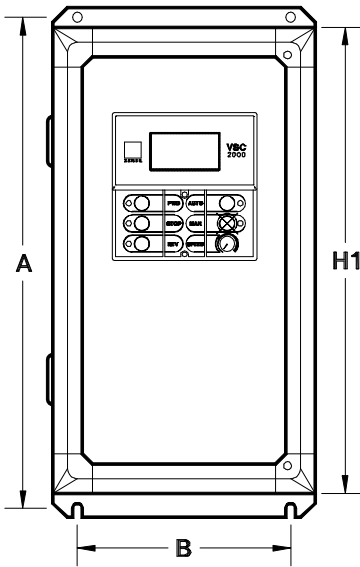

Dimensions		
	mm	in
A	495	19.5
B	215	8.5
H1	470	18.5
H2	515	20.3
D1	236	9.3
D2	269	10.6
W	265	10.4

⊗ Centre of Gravity

- 210 from top (Dim. H2)
- 100 from right (Dim. W)
- 80 from back (Dim. D1)

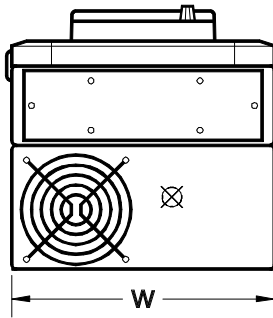

04996-01



- Mounting holes are 10mm (0.4") diameter.
- Dimension tolerance is ±1.0mm (±0.04").
- A kit is available for through-panel mounting the chassis.

✓ UL applies or ^ UL is pending

Models				
Model Number	Input Voltage	Cont. Current	Gross Weight*	
			kg	lb
VSC-2A16	240 V	16 A	26	57
VSC-2A27	240 V	27 A	30	66
VSC-2A41	240 V	41 A	32	71
✓VSC-2G14	480 V	14 A	26	57
✓VSC-2G27	480 V	27 A	30	66
✓VSC-2G41	480 V	41 A	32	71
^VSC-2J14	600 V	14 A	30	66
^VSC-2J27	600 V	27 A	32	71

* Weights shown include packaging
 For drive net weight subtract 3 kg (6.6 lb) of packing material. Crate dimensions: W x H x D
 380 x 610 x 400 mm, 15.0 x 24.0 x 15.8 inches.

IMPORTANT

1. The VSC 2000 must be mounted in a vibration free location.
2. Allow 100mm above, below and either side of each enclosure for ventillation.
3. Mount the VSC 2000 vertically away from heat radiating sources.
4. Do not mount the VSC 2000 in direct sunlight or on hot surfaces.
5. If the VSC 2000 is mounted inside another enclosure, the total heat dissipation must be allowed for.
6. Remove gland plate before drilling cable holes.
7. Do not allow metal shavings or any other conductive material to enter the enclosure or damage may result.

VSC Medium Chassis Mechanical Installation Diagrams

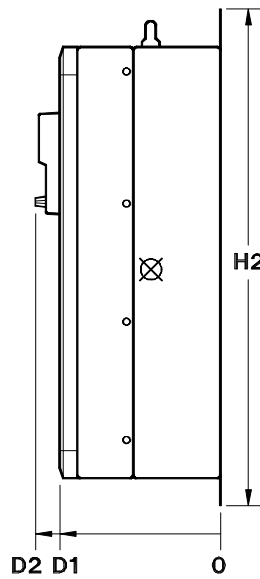
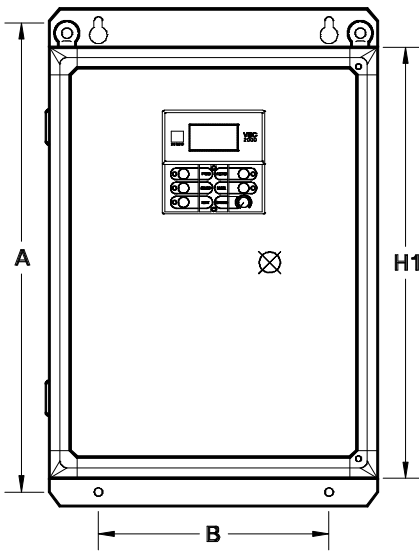

Dimensions		
	mm	in
A	677	26.7
B	330	13.0
H1	620	24.4
H2	715	28.1
D1	298	11.7
D2	331	13.0
W	470	18.5

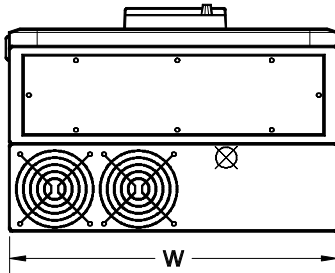

05096-01

Centre of Gravity

- 375 from top (Dim. H2)
- 190 from right (Dim. W)
- 100 from back (Dim. D1)

✓ UL is pending on these models

- Mounting holes are 12mm (0.48") diameter.
- Dimension tolerance is $\pm 1.0\text{mm}$ ($\pm 0.04"$).
- A kit is available for through-panel mounting the chassis.
- Eyebolt inside diameter is 12.5mm (0.5").

Models

Model Number	Input Voltage	Cont. Current	Gross Weight*	
			kg	lb
VSC-2A55	240 V	55 A	65	144
VSC-2A82	240 V	82 A	72	159
VSC-2A109	240 V	109 A	77	170
✓ VSC-2G55	480 V	55 A	65	144
✓ VSC-2G82	480 V	82 A	72	159
✓ VSC-2G109	480 V	109 A	77	170
✓ VSC-2J41	600 V	41 A	65	144
✓ VSC-2J55	600 V	55 A	72	159
✓ VSC-2J82	600 V	82 A	77	170

*Weights shown include packaging.

For drive net weight subtract 10 kg (22 lb) of packing material. Crate dimensions: W x H x D 520 x 750 x 440 mm, 20.5 x 29.5 x 17.3 inches.

IMPORTANT

1. The VSC 2000 must be mounted in a vibration free location.
2. Allow 100mm above, below and either side of the enclosure, for each enclosure for ventilation.
3. Mount the VSC 2000 vertically away from heat radiating sources.
4. Do not mount the VSC 2000 in direct sunlight or on hot surfaces.
5. If the VSC 2000 is mounted inside another enclosure, the total heat dissipation must be allowed for.
6. Remove gland plate before drilling cable holes.
7. Do not allow metal shavings or any other conductive material to enter the enclosure or damage may result.

VSC Large Chassis Mechanical Installation Diagrams

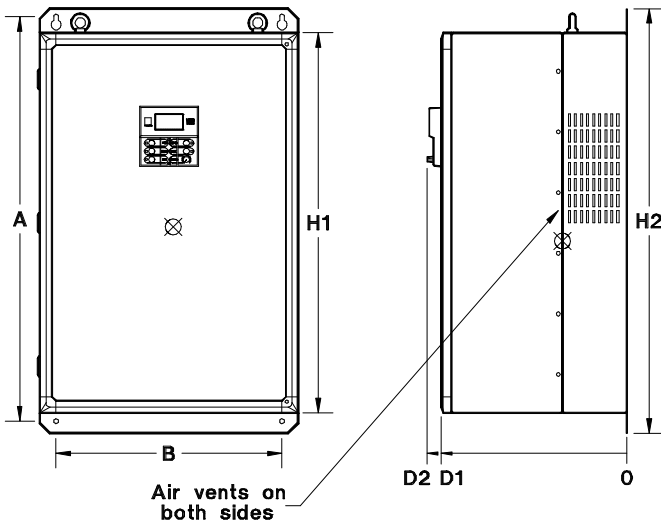

Dimensions		
	mm	in
A	1000	39.4
B	536	21.1
H1	940	37.0
H2	1050	41.3
D1	458	18.0
D2	491	19.3
W	620	24.4

500 from top (Dim. H2)
 310 from right (Dim. W)
 160 from back (Dim. D1)



Centre of Gravity

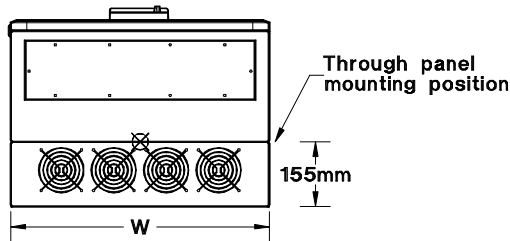

05196-01

- Mounting holes are 12mm (0.48") diameter.
- Dimension tolerance is $\pm 1.0\text{mm}$ ($\pm 0.04"$).
- A kit is available for through-panel mounting the chassis.
- Eyebolt inside diameter is 25mm (1.0").

IMPORTANT

1. The VSC 2000 must be mounted in a vibration free location.
2. Allow 100mm above, below and either side of each enclosure for ventilation.
3. Mount the VSC 2000 vertically away from heat radiating sources.
4. Do not mount the VSC 2000 in direct sunlight or on hot surfaces.
5. If the VSC 2000 is mounted inside another enclosure, the total heat dissipation must be allowed for.
6. Remove gland plate before drilling cable holes.
7. Do not allow metal shavings or any other conductive material to enter the enclosure or damage may result.

VSC 2000 Chassis 4 Power Terminal Locations For a Bus Bar Connected Installation

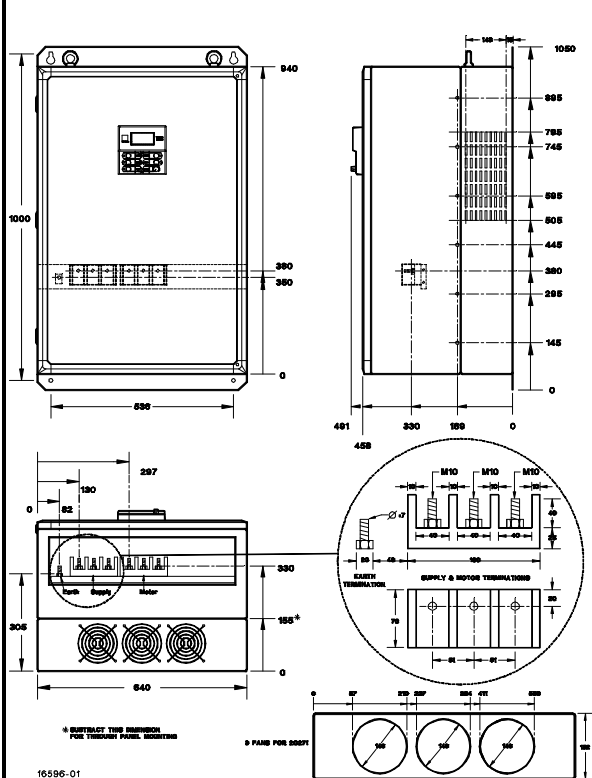

16596-01

Models

VSC Model	Input Voltage	Cont. Current	Gross Weight*	
			kg	lb
VSC2A143	240 V	143 A	170	375
VSC2A190	240 V	190 A	211	465
VSC2A203	240 V	203 A	215	474
VSC2A271	240 V	271 A	222	490
VSC2G143	480 V	143 A	170	375
VSC2G190	480 V	190 A	211	465
VSC2G203	480 V	203 A	215	474
VSC2G271	480 V	271 A	222	490
VSC2J109	600 V	109 A	170	375
VSC2J143	600 V	143 A	211	465
VSC2J190	600 V	190 A	215	474
VSC2J203	600 V	203 A	222	490

*Weights shown include packaging

For drive net weight subtract 45 kg (99 lb) of packing material. Crate dimensions: W x H x D, 760 x 1150 x 640 mm, 29.9 x 45.3 x 25.2 inches.

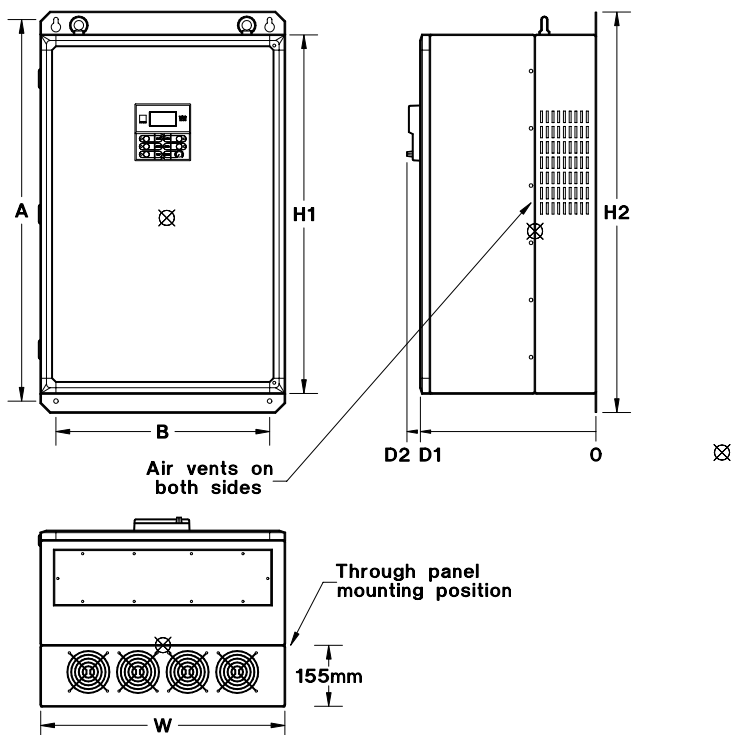

Dimensions		
	mm	in
A	1000	39.4
B	536	21.1
H1	940	37.0
H2	1050	41.3
D1	458	18.0
D2	491	19.3
W	620	25.2
W1*	641	25.2

Centre of Gravity
500 from top (Dim. H2)
310 from right (Dim. W)
160 from back (Dim. D1)

05196-01

- Mounting holes are 12mm (0.48") diameter.
- Dimension tolerance is $\pm 1.0\text{mm}$ ($\pm 0.04"$).
- A kit is available for through-panel mounting the chassis.
- Eyebolt inside diameter is 25mm (1.0").

IMPORTANT

1. The VSC 2000 must be mounted in a vibration free location.
2. Allow 100mm above, below and either side of each enclosure for ventilation.
3. Mount the VSC 2000 vertically away from heat radiating sources.
4. Do not mount the VSC 2000 in direct sunlight or on hot surfaces.
5. If the VSC 2000 is mounted inside another enclosure, the total heat dissipation must be allowed for.
6. Remove gland plate before drilling cable holes.
7. Do not allow metal shavings or any other conductive material to enter the enclosure or damage may result.

VSC Model	Cont. Current	RMS Input Current		Max. Fuse or C/B Rating	Gross Weight		Enclosure Rating	Max. Ambient	
		Cont.	Int.		kg	lb		°C	°F
VSC-2G300	300A	300A	330A	350A	226	497	IP55	45	113
VSC-2G340	340A	340A	374A	400A	240	528	IP55	40	104
VSC-2G360	360A	360A	396A	450A	245	539	IP54	40	104
VSC-2G406	406A	406A	447A	500A	250	550	IP54	40	104

Weights Shown include packaging. For drive net weight subtract 45 kg (99 lb) of packing material.

Crate dimensions: W x H x D, 760 x 1150 x 640 mm (29.2 x 45.3 x 25.2 in)

* Dimension W1 applies only to IP54 drives

All other parameters are as per the VSC 2000 General Specifications

VSC 2000 Electrical Installation Diagram

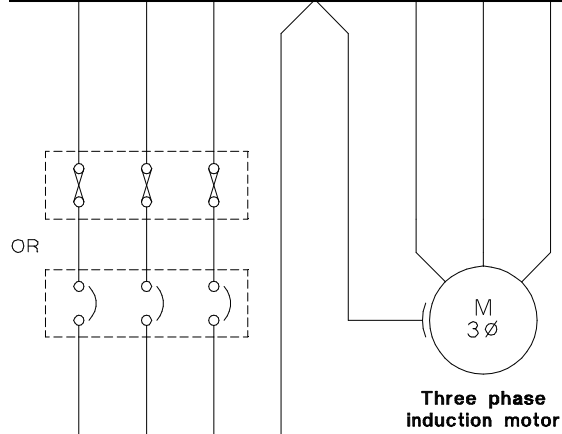
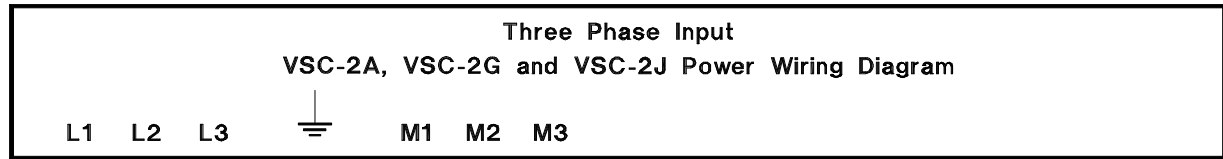

For compliance with EMC standards, the motor wiring and ground conductor must be enclosed together in a continuous metallic sheath or conduit which has good contact to both the motor and the inverter chassis.
The sheath shall contain only the wiring from one inverter and its associated motor cables. No other conductors may be included.

Motor Voltage	VSC-2A: 208, 220, 230, 240 Vac
	VSC-2G: 346, 380, 415, 440, 460, 480 Vac
	VSC-2J: 440, 460, 480, 575, 600 Vac
Output voltage cannot exceed input voltage.	

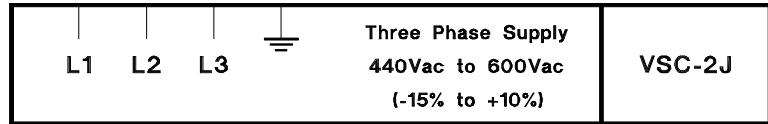
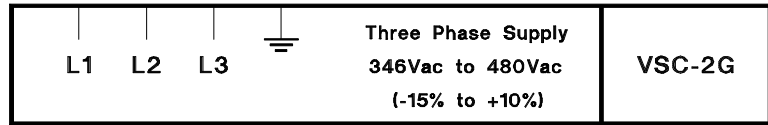
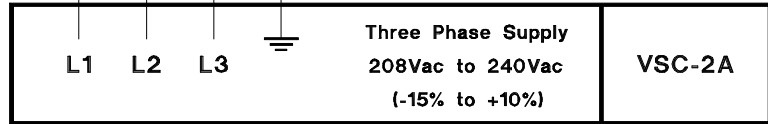

IMPORTANT

1. Either fuses or a circuit breaker should be connected as shown. Fast semiconductor fuses are not required.
2. Cable sizes should be selected according to local codes or standards.
3. For complete motor thermal protection microtherms or thermistors should be installed in the motor winding.

04696-01

Maximum Fuse and Circuit Breaker Ratings

Model Numbers			RMS Input Current (A)		Fuse or C/B Rating (A)
240V	480V	600V	Continuous	Intermittent	
	VSC-2G14	VSC-2J14	14.0	15.4	32
VSC-2A16			16.0	18.7	32
VSC-2A27	VSC-2G27	VSC-2J27	27.0	29.7	40
VSC-2A41	VSC-2G41	VSC-2J41	41.0	45.1	63
VSC-2A55	VSC-2G55	VSC-2J55	55.0	60.5	80
VSC-2A82	VSC-2G82	VSC-2J82	82.0	90.2	150
VSC-2A109	VSC-2G109	VSC-2J109	109.0	119.9	150
VSC-2A143	VSC-2G143	VSC-2J143	143.0	157.3	200
VSC-2A190	VSC-2G190	VSC-2J190	190.0	209.0	250
VSC-2A203	VSC-2G203	VSC-2J203	203.0	223.3	250
VSC-2A271	VSC-2G271		271.0	298.1	350

Terminal Configurations

The **VSC 2000 Control Wiring Diagrams** , show examples of suitable field wiring. The Control terminal strip (terminals 40 to 47) can be configured via the CCS Touch Screen as either Industrial, HVAC or Enhanced Terminals. These Configurations are described in the Terminal Configuration tables below. *Note that some Control input terminal assignments vary slightly between configurations!* The VSC 2000 is factory set for Industrial Terminals. See **Drive Configuration** for how to select HVAC or Enhanced Terminals from CCS Touch Screen. It is recommended you do not power up the drive until the **VSC 2000 Start Up Procedure** and **Adjustment Procedure** have been read and understood.

To operate the drive from local Comprehensive Control Station (CCS) controls, the Enable control input must be *high* ie. terminals 40 and 48 are connected. The MAN-ual button, when pressed, sets the CCS to Manual mode, then the FWD, REV, STOP buttons and SPEED potentiometer are available. The STOP, MAN-ual buttons and SPEED pot. can also be available in Auto mode, if enabled via the touch screen in the COMPLETE SETUP menu. The default setting is Stop enabled in Auto -see **CCS IN AUTO** in the **VSC 2000 User's Manual** .

From the examples in the **Control Wiring Diagrams** , it is important to note the following:

- * All of the Control inputs are *high* when connected to 24V dc and *low* when open circuit or connected to Digital Common.
- * Trip Reset inputs are edge triggered by either positive or negative going edges. Forward and Reverse Control inputs are internally latched, so do not need to be held *high* once set. All other Control inputs are level dependent and must be held *high* or *low* to be valid.
- * All wiring examples show that the Enable, Run/Stop must be held *high*, and a direction (Forward or Reverse) set for the drive to run at the speed set by the selected speed reference.
- * When Enable goes low, the drive will immediately stop operating, ie. no output and the motor will coast to a stop. Enable therefore can also be an *Emergency Stop* input.
- * When Run/Stop goes low, the drive will either Ramp to Stop, Coast to Stop or apply DC Braking, according to the *DRIVE STOPPING* mode selected in *COMPLETE SETUP*.
- * When a trip condition occurs, the drive will immediately stop and the motor will coast to a stop. If the trip condition has passed, the trip can be cleared by the rising or falling edge of the Trip Reset input (*edge triggered*).

Industrial Terminal Configuration

Terminal Number	Name	Function
40	Control Input A	Enable
41	Control Input B	Trip Reset (edge triggered)
42	Control Input C	▲Run/Stop
43	Control Input D	▲Forward (Internally latched)
44	Control Input E	▲Reverse (Internally latched)
45	Control Input F	▲Jog
46	Control Input G	▲Speed Reference Select
47	Control Input H	▲Speed Reference Select
48	+24V	
49	+24V	
50	DIG COM (24V com)	Digital Common for 24V supply

Speed Reference	Control Input G	Control Input H
IN 1 (11,12)	Low	Low
IN 2 (14,15)	High	Low
Preset Speed 1	Low	High
Preset Speed 2	High	High

All of the control inputs are high when connected to +24Vdc and low when open circuit or connected to Digital Common

NOTE: Additional Digital Outputs are available if an Extended Features Board is used.

▲These Control Inputs active in AUTO mode only.

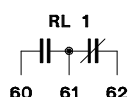

No input power.	Open	Closed
Power on, drive stopped.	Open	Closed
Power on, drive enabled and direction selected.	Closed	Open

Run Relay RL 1

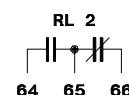

No input power.	Open	Closed
Power on, no trip.	Open	Closed
Power on, trip detected.	Closed	Open

Trip Relay RL 2

Terminal Configurations (Cont.)

HVAC Terminal Configuration

Terminal Number	Name	Function
40	Control Input A	Enable
41	Control Input B	Trip Reset (edge triggered)
42	Control Input C	▲Run/Stop
43	Control Input D	▲Forward (Internally latched)
44	Control Input E	▲Reverse (Internally latched)
45	Control Input F	Essential Services O'vrde/ ▲Jog
46	Control Input G	▲Speed Reference Select
47	Control Input H	▲Speed Reference Select
48	+24V	
49	+24V	
50	DIG COM (24V)	Digital Common for 24V supply

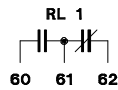

No input power.	Open	Closed
Power on, trip detected.	Open	Closed
Power on, drive enabled and no trip.	Closed	Open

Proof Relay RL 1

Speed Reference	Control Input G	Control Input H
IN 1 (11,12)	Low	Low
IN 2 (14,15)	High	Low
Preset Speed 1	Low	High
Preset Speed 2	High	High

All of the control inputs are high when connected to +24Vdc and low when open circuit or connected to Digital Common.

NOTE: Additional Digital Outputs are available if an Extended Features Board is used.

▲ These Control Inputs active in AUTO mode only.

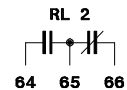

No input power.	Open	Closed
Power on, ESO not selected.	Open	Closed
Power on, ESO selected.	Closed	Open

ESO Relay RL 2

Enhanced Terminal Configuration

Terminal Number	Name	Function
40	Control Input A	Enable/Trip Reset -(edge trig.d)
41	Control Input B	Ramp 1/Ramp 2
42	Control Input C	▲Run/Stop
43	Control Input D	▲Forward (Internally latched)
44	Control Input E	▲Reverse (Internally latched)
45	Control Input F	▲ Speed Reference Select
46	Control Input G	▲Speed Reference Select
47	Control Input H	▲Speed Reference Select
48	+24V	
49	+24V	
50	DIG COM (24V)	Digital Common for 24V supply
*80	Control Input J	Increase Speed (Motorized Pot)
*81	Control Input K	Decrease Speed (Motorized Pot)
*82	Control Input L	▲Jog
*83	Control Input M	▲PID Close Loop
*84	+24V	
*85	DIG COM (24V)	Digital Common for 24V supply

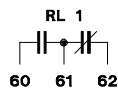

No input power.	Open	Closed
Power on, drive stopped.	Open	Closed
Power on, drive enabled and direction selected	Closed	Open

Run Relay RL 1

Speed Reference	Control Input F	Control Input G	Control Input H
IN 1 (11,12)	Low	Low	Low
IN 2/Motorized Pot*	Low	Low	High
Preset Speed 1	Low	High	Low
Preset Speed 2	Low	High	High
Preset Speed 3	High	Low	Low
Preset Speed 4	High	Low	High
Preset Speed 5	High	High	Low
Preset Speed 6	High	High	High

All of the control inputs are high when connected to +24Vdc and low when open circuit or connected to Digital Common.

NOTE: * Motorized Pot requires the Extended Features (EF)Board. Control Inputs J and K (80 & 81) replace IN 2 as speed reference when *MOTORIZED POT* function is enabled from the *COMPLETE SETUP* menu.

▲ These Control Inputs active in AUTO mode only

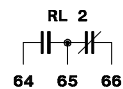

No input power.	Open	Closed
Power on, no trip.	Open	Closed
Power on, trip detected.	Closed	Open

Trip Relay RL 2

VSC 2000 Control Wiring Diagrams

INDUSTRIAL/HVAC TERMINALS

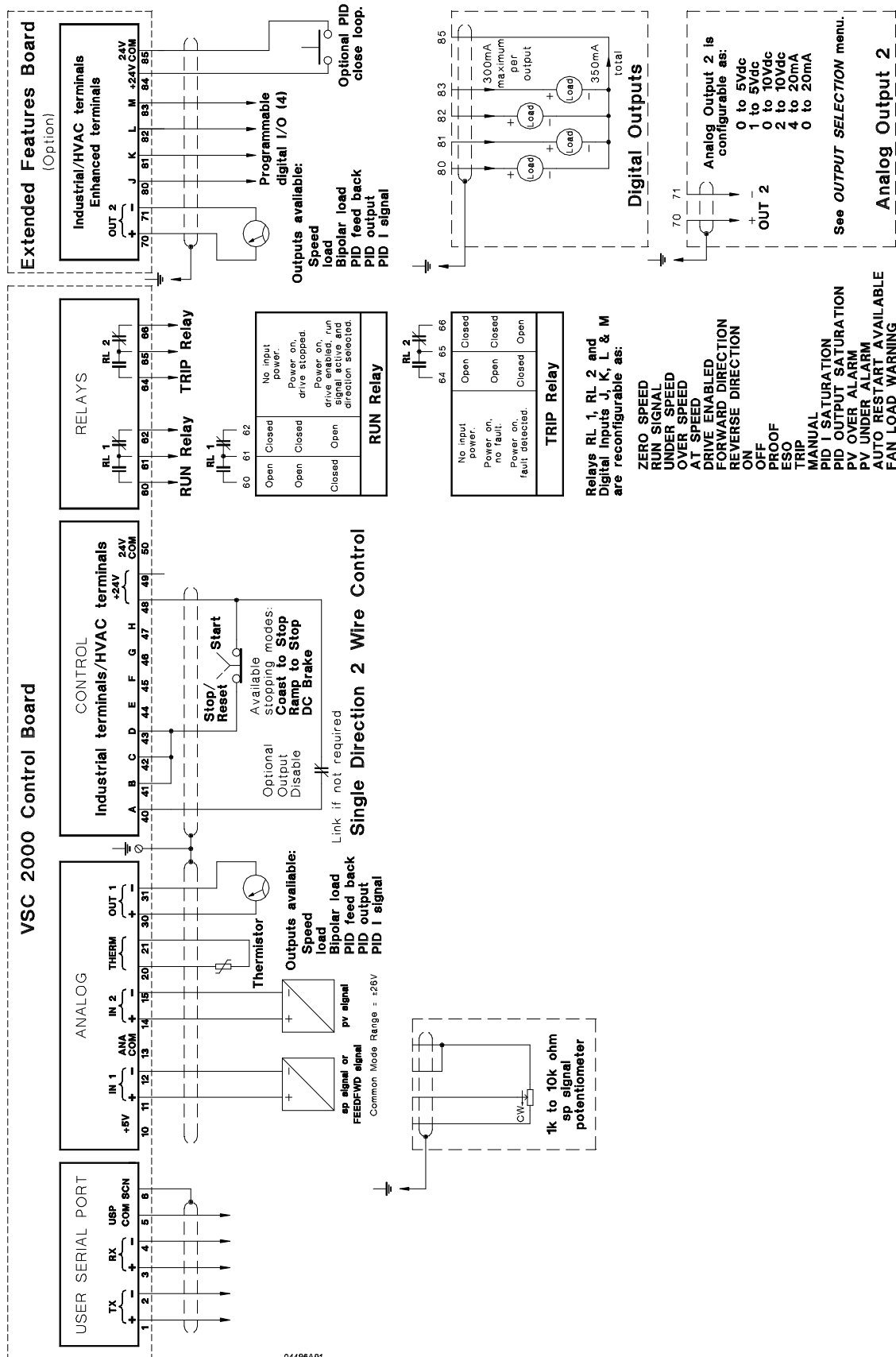

04496A01

INDUSTRIAL/HVAC TERMINALS (Continued)

- IMPORTANT**
1. Keep low voltage control wiring separated from power cabling in accord with good electrical practise.
 2. Shielded cable is recommended for control wiring connected to terminals 10 through 85, except 60 to 66, and must be used for terminals 1 through 5.
 3. The shield wire should be terminated at one end only, preferably to the ground at the VSC_2000. A ground connection is provided on the control board and terminal 6 (SCN) is internally connected to ground.
 4. Contacts must be "Voltage Free".
 5. Control contacts must be suitable for use at 10mA and 24Vdc.
 6. CONTROL terminal is shown for either **INDUSTRIAL TERMINALS** or **HVAC TERMINALS** -See pages 8 and 9. Select terminals from **DRIVE CONFIG** menu -See pages 15 and 16.

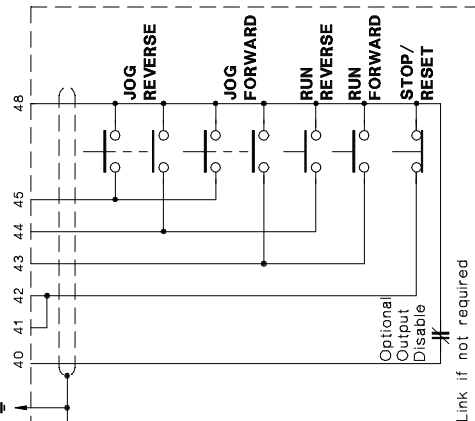
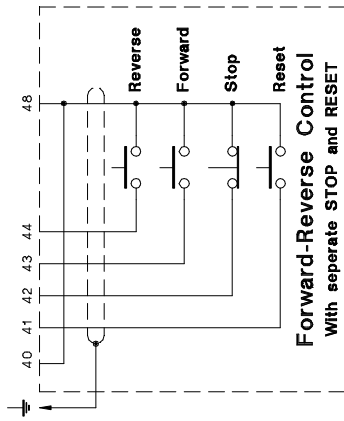

Run speed reference is IN 1 (default). Jog speed reference is IN 2.

Alternatively, jog speed reference can be internally preset to any value between min and max frequency. Set **JOG SPEED** and **SOURCE** from the **JOG SPEED** menu. Then the jog pot is no longer required.

Forward - Reverse Control with Jog

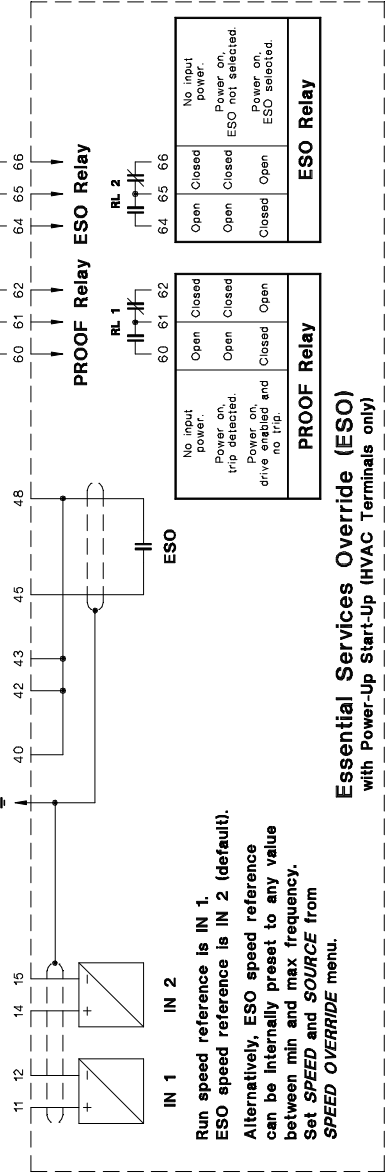

Run speed reference is IN 1.
ESO speed reference is IN 2 (default).
Alternatively, ESO speed reference can be internally preset to any value between min and max frequency. Set **SPEED** and **SOURCE** from **SPEED OVERRIDE** menu.

04496-02

ENHANCED TERMINALS

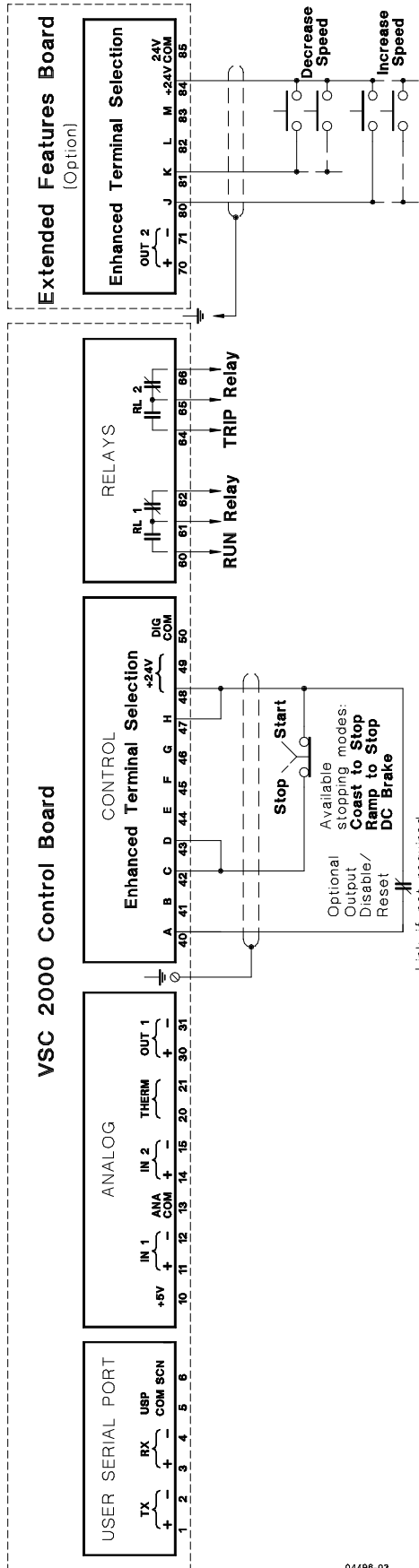

04498-03

Single Direction Control with Motorized Pot

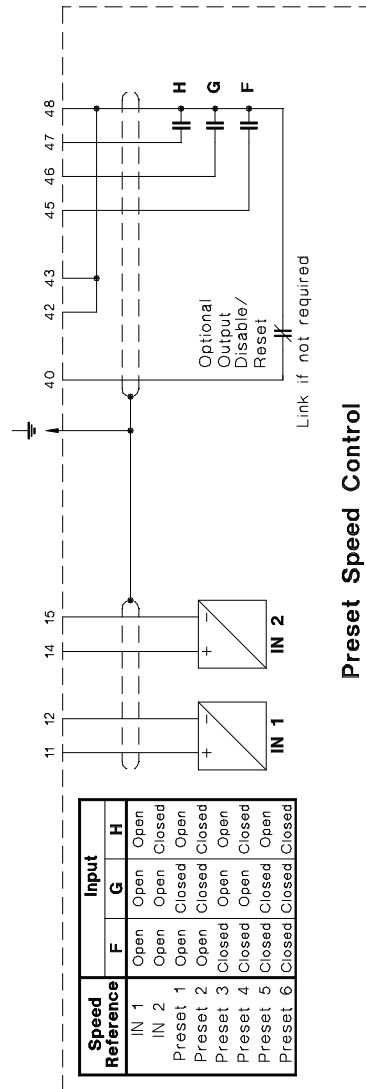
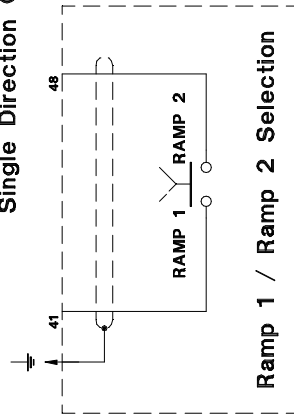

Speed Reference	Input		
	F	G	H
IN 1	Open	Open	Open
IN 2	Open	Open	Closed
Preset 1	Open	Closed	Open
Preset 2	Open	Closed	Open
Preset 3	Closed	Open	Open
Preset 4	Closed	Open	Open
Preset 5	Closed	Closed	Open
Preset 6	Closed	Closed	Closed

IMPORTANT

1. Keep low voltage control wiring separated from power cabling in accord with good electrical practise.
2. Shielded cable is recommended for control wiring connected to terminals 10 through 85, except 60 to 66, and must be used for terminals 1 through 5.
3. The shield wire should be terminated at one end only, preferably to the ground at the VSC 2000. A ground connection is provided on the control board and terminal 6 (SCN) is internally connected to ground.
4. Contacts must be "Voltage Free".
5. Control contacts must be suitable for use at 10mA and 24Vdc.
6. CONTROL terminal is shown for ENHANCED TERMINALS only, -See pages 8 and 9. Select terminals from DRIVE CONFIG menu-See pages 15-16.

Start-Up Procedure

Warning : Ensure that input power supply has been removed and the filter capacitors are fully discharged before attempting any work inside the VSC 2000.

For safety wear a face shield when working inside VSC 2000 enclosure if power is applied or close covers.

Connect the input wiring and the motor wiring to the VSC 2000 as shown in the **Electrical Installation Diagram** . *At this point the VSC 2000 is ready to run a motor!* Before applying power it is recommended that the **Adjustment Procedure** below, be read and understood to ensure safe operation of the drive-motor configuration. Before running a motor, ensure that the direction of rotation will not damage machinery or harm personnel.

On application of power to the VSC 2000 the LEDs on the Comprehensive Control Station (CCS) will flash momentarily. The Zener logo will appear on the LCD touch screen for three seconds, then the Run Screen (fig 1) will be displayed.

If a message appears at the bottom of this display it could mean that a trip has occurred. Refer to **Messages** and **Trouble Shooting Guide** for details on possible faults and remedies.

The CCS front panel will have an amber LED indicating MANUAL mode and a red LED indicating STOP.

To run the motor it is now only a matter of setting the CCS SPEED pot to minimum (anti clockwise) and pushing the FWD button. Slowly rotate the speed pot clockwise and check motor for rotation. If the rotation is in the wrong direction, press STOP, disconnect power and wait for capacitors to fully discharge; swap any two motor phase wires and then re-apply power and press FWD.

Adjustment Procedure

The Comprehensive Control Station (CCS) is the interface between the user and the drive. It has local front panel controls as well as the *Touch Screen* programming interface. The brief instructions below will acquaint the user with the CCS and how to use it. Most user parameters can be adjusted while the drive is running a motor, however, safety should always be the first consideration.

The user is encouraged to navigate the menus without fear of damage to the drive, however, care must be taken to ensure any equipment connected to the motor will not be damaged nor harm personnel.

A simple method of resetting the drive to factory settings is described in **Restoring Factory Settings** .

Using the Touch Screen

The Run Screen (Fig. 1) always appears a few seconds after powering up the VSC 2000.

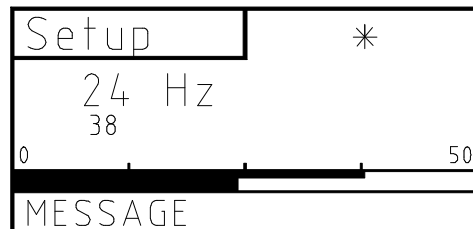

Figure 1 Run Screen

Touching the screen over the word *Setup* will take the CCS into the menu system (Fig. 2). To return back to the Run Screen, press the *Run* button.

Run	QUICK SETUP
Help	COMPLETE SETUP
▼	LANGUAGE
Exit	DISPLAY

Figure 2 Menu System

Adjustment Procedure (Cont.)

The menu system is arranged as a hierarchal structure. It is necessary to descend down the menus to adjust drive or user parameters. To return back up a level in the menu hierarchy, use the *Exit* button. When the *Run* button is available, it can be used to jump to the Run Screen from any level in the menu hierarchy.

Entering Motor Nameplate Information

The following steps serve as an example of how to use the Touch Screen and are beneficial in commissioning the VSC 2000. The four motor parameters of interest for setting up the drive are: voltage, current, frequency and nameplate speed (not synchronous speed). As an example, say a motor has the following parameters:

Voltage: 460V
 Rated Current: 11A
 Frequency: 50Hz
 Nameplate Speed: 1440RPM

To enter this information into the drive, go into the VSC 2000's menu system by pressing the *Setup* button. From there, a selection on the right hand column will contain *QUICK SETUP*. Select this by pressing over the words. Now the items on the right hand column are *MOTOR*, *RAMP*, *MINIMUM FREQUENCY* and *MAXIMUM FREQUENCY*. Press *MOTOR* to enter the Motor menu.

MOTOR	MOTOR VOLTAGE
Help	NAMEPLATE CURRENT
	MOTOR FREQUENCY
Exit	NAMEPLATE SPEED RPM

Figure 3 MOTOR Menu

Now select *MOTOR VOLTAGE* and examine the values listed in the right-hand column.

Press the ▼ button to see more values. Press *CUSTOM* to type in a value manually.

MOTOR VOLTAGE		1	2	3
4 15		4	5	6
<		>	7	8 9
Cancel			0	⌂

Figure 4 CUSTOM screen for MOTOR VOLTAGE

For example, to manually enter 460 as the motor voltage, just start pressing the numbers on the keypad. Use the < key to backspace, the > to move forward. To save the value and exit, press *MOTOR VOLTAGE*. The *CANCEL* is to exit without changing the original value. After pressing *MOTOR VOLTAGE* or *CANCEL* press the *EXIT* button to return to the *MOTOR* menu.

Now enter rated current by pressing *NAMEPLATE CURRENT* and keying in 11. Save the value by pressing *NAMEPLATE CURRENT*.

Select *MOTOR FREQUENCY* and press 50Hz. Press the *MOTOR FREQUENCY* button in the top left or *EXIT* to return back to the *MOTOR* menu.

Next, press the *NAMEPLATE SPEED RPM* button and key in 1440. Return to the *MOTOR* menu and then press *MOTOR* or *EXIT* and then *EXIT* again to get to the Run Screen.

That completes the entry of motor parameters. In a similar manner all other parameters are programmed into the drive. Using the *EXIT* key returns to the top of the menu system (figure 2). Pressing *Run* will cause a jump back to the Run screen but the complete setup menu will not be exited completely.

Adjustment Procedure (Cont.)

The VSC 2000 can be configured to suit different applications. Industrial Terminals is the general purpose configuration, and Enhanced Terminals is an extension of this, offering additional input\outputs and features. HVAC Terminals offers special purpose Control inputs and operating features. Refer to the three different terminal assignment tables on pages 8 to 9, and the **Control Wiring Diagrams** on pages 10 to 12 to see how the configurations differ in use.

WARNING : Terminal Configuration should not be changed in an already installed drive system unless the Control Wiring is set up for the Terminals selected. Terminals assignments (terminals 40 to 47) differ slightly between configurations. Unexpected drive system operation may result otherwise.

Drive Configuration

Two examples of simple setup procedures are now described. For most industrial applications a ramp time and minimum and maximum speeds might be the only settings required. Follow the **Industrial Setup** for this. If the VSC 2000 is in an HVAC installation follow instructions for the **HVAC Setup** and then proceed to the **Industrial Setup**.

To configure the drive, firstly set the Terminals assignment to match the Control Wiring installed. Go to the *COMPLETE SETUP* menu, press the ▼ button until *DRIVE CONFIG* appears and press it. Now press *SELECT TERMINALS*. A warning will appear. Read this, press *OK*, then choose either *INDUSTRIAL -*, *HVAC -*, or *ENHANCED TERMINALS*. A new screen appears asking for confirmation - press *OK*. Press *EXIT*, then *SET CUSTOM DEFAULTS* and then *OK*. Press *EXIT* three times to exit the *COMPLETE SETUP* menu.

Motor Parameters

Enter the motor nameplate information, after the drive configuration has been set (see **Entering Motor Nameplate Information**)

HVAC Setup

Drive CONFIG - HVAC terminals

Firstly, ensure *HVAC TERMINALS* are selected from the *DRIVE CONFIG* menu and *SET CUSTOM DEFAULTS* is pressed. This will make essential services functions available and provide a 60 second ramp and ESO and PROOF relay assignments.

Auto Restart

WARNING : AUTO RESTART can make the VSC 2000 start without warning. It is very important for all personnel to be protected from any machinery driven by the VSC 2000 with AUTO RESTART enabled.

From the *COMPLETE SETUP* menu, press the ▼ button until *AUTO RESTART* appears as a menu item. To set the number of restarts allowed within a certain period, called the Reset Time, press *NUMBER OF RESTARTS*. Enter a value (minimum of 2 to a maximum of 15). Then set the *RESET TIME* for a desired value. The minimum time is 1 minute and maximum is 20 minutes. Finally press *ENABLE* and then *EXIT*.

Essential Services Override (ESO)

WARNING : With ESO engaged the VSC 2000 can only be stopped by opening control input F and applying a stop signal.

(Essential Services enabled and Control Input F *high*) the *ENABLE*, *RUN/STOP* and the *Comprehensive Control Station STOP* (*AUTO* or *MAN*) are disabled. All thermal trips are ignored and all other trips are *AUTO RESTARTED* indefinitely. Warranty may be void if the drive gets over-stressed (ie. if any trips are ignored) during ESO.

The *SPEED OVERRIDE* menu in the *COMPLETE SETUP* menu contains ESO parameters. Ensure that *HVAC TERMINALS* have been selected prior to making these adjustments. When correctly setup, the VSC 2000 on a *high* to Control Input F (eg via contact closure) will drive the motor at a set speed, disregarding internal thermal trips and auto restarting all other trips indefinitely.

Monitoring Drive Output

To enable this function, press *ESSENTIAL SERVICES* and *ENABLE*. Read the warning message and press OK. Then enter a security number. This number is 1470. Now select a *SPEED SOURCE*, either *OVERRIDE PRESET* or *INPUT 2*. Override Preset is a fixed speed value that you enter, Input 2 is the second analog input IN 2 (14,15) which is an *external* speed reference.

TIME ENABLED displays when Essential Services were enabled. TIME STRESSED displays when an internal trip occurred that was ignored during ESO.

To adjust more functions, read the Industrial Setup or consult the **User's Manual**.

Industrial Setup

INDUSTRIAL TERMINALS is the default drive configuration. The *QUICK SETUP* menu provides access to the ramp time, minimum and maximum speeds. To begin adjustments, from the Run Screen, press *SETUP*, then press *QUICK SETUP*.

Ramp time

To adjust the ramp time, press *RAMP* in the *QUICK SETUP* menu. Either select a value from the given choices or press *CUSTOM* to manually enter another value in seconds. Valid times are 0.5 to 600 seconds.

Minimum Speed

To enter a minimum speed, press *MINIMUM FREQUENCY* and then enter the desired value. The range of values can be from 0Hz to 5Hz less than the current maximum frequency value.

Maximum Speed

To set the maximum frequency in hertz, a number of values are available as well as the custom entry. The range of acceptable values is 5Hz to 200Hz. Make a selection and then EXIT back to the Run Screen.

Reverse Direction

If reverse direction is required it must be enabled first. EXIT from the *QUICK SETUP* menu. Enter the *COMPLETE SETUP* menu to find *REVERSE DIRECTION* as the bottom item on the IM02000H

first page. Press *REVERSE DIRECTION* and then *ENABLE*. Now press *EXIT*.

Current Limit

To ensure that the motor does not draw more than its rated current, current limit should be set to a value near rated motor current. The value is a percentage of drive rated current, eg. a VSC-2G41 is a 41A unit. So a 100% current limit point will limit output to the motor to 41A. Press *CURRENT LIMIT* and enter a value. Then *EXIT*.

Thermal Protection

From the *COMPLETE SETUP* menu, press the button until *THERMAL PROTECTION* appears on the menu. Select it. If a microtherm, thermal overload or thermistor is fitted to the motor and it is wired up to terminals 20 and 21, then press *THERMAL DEVICE* to choose *THERMISTOR* or *MICROTHERM* (use *MICROTHERM* for thermal overloads). Then *EXIT* and press *THERMAL TRIP* then *ENABLE* and *EXIT*.

When external motor thermal protection is fitted, I²t protection which is enabled by default, can be disabled by pressing *I²t PROTECTION* and then *DISABLE*. I²t is not suitable if multiple motors are being driven but can be an alternative to external motor thermal protection with single motors. It is default enabled and set to drive rated current. To adjust the I²t value, press *I²t* and enter the desired value as a percentage of motor nameplate current (as entered in *MOTOR* menu).

Check each value again and make any corrections.

Monitoring Drive Output

Important parameters can be individually displayed on the Run screen in an area of the display set aside to display these quantities. By touching the screen on the rotation symbol * in the top right corner as shown in figure 5 the drive's output current will be displayed. The rotating symbol * is otherwise displayed.

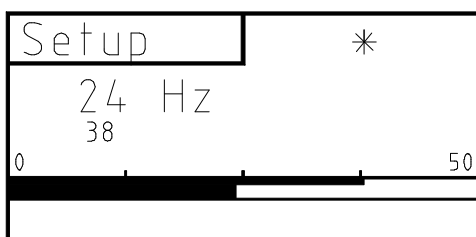

Figure 5 Touch the rotation symbol * to display output quantities

By touching again, the quantity will change to DC bus voltage. Further pressing will scroll through, output power, % load and then back to the rotating symbol.

Alternatively, all these quantities can be displayed simultaneously on the *METER READOUTS* screen. To get this display to come up, press *SETUP*, scroll down once (▼), then press *METER READOUTS*. To return to the Run Screen, press *SETUP* and then *RUN*. The quantities displayed are in the following units.

Output frequency	Hz
Output Current	Amps
DC Bus Voltage	Vdc
Output power	kW
Output load	% of full load

Restoring Factory Settings

This feature can be used to restore the drive back to a known group of settings after having made changes to the Setup via the CCS Touch Screen.

Stop the drive before restoring factory settings. Ensure that the DIP switch (SW1) on the back of the CCS is open or off (default position). If the CCS is in a menu, press the *EXIT* button repeatedly until the Run Screen appears - do not use the *RUN* button. If the CCS is already in the Run Screen press *SETUP* and then use the *EXIT* button repeatedly to return to the Run Screen.

Now press *SETUP* to enter the menu system - the screen should look like that shown in figure 2. If not repeat the above instructions.

Press the following buttons:

COMPLETE SETUP

▼ (3 times)

DRIVE CONFIG

RESTORE DEFAULTS

OK

EXIT (3 times)

The CCS should now display the Run Screen - see figure 1.

*For further in-depth information about the VSC 2000 Touch Screen programmable features consult the **VSC 2000 User's Manual** section.*

Maintenance Procedure

There is little maintenance required on the VSC 2000 as it has no moving parts other than the cooling fans. Items that can be checked periodically are:

Check fans for quiet rotation and air vents for free air flow. Remove any excess dust by vacuuming. This should

be done periodically, depending on dust in the location.

Annually inspect inside the drive for signs of excess heating ie discolouration of any components and for any swelling or distortion of capacitors. Contact your ZENER supplier if there are any concerns.

Messages

These messages will cause the VSC 2000 to trip and not restart until a Trip Reset signal is activated or Auto restart is enabled.

Message	Meaning
Over Current	One of the outputs has exceeded maximum current.
Over Voltage	Input voltage or bus voltage has exceeded maximum value.
Under Voltage	Bus voltage has fallen below minimum threshold.
Phase Failure	Input voltage has a phase missing or is low.
INTERNAL TOO HOT	Drive is too hot.
HEATSINK TOO HOT	Power devices inside drive are too hot.
Motor Overload I ² t	An I ² t trip has occurred.
Ground Fault	A ground fault has occurred on the output.
Motor Too hot	A Thermistor/microtherm has indicated motor hot.
Thermistor Shorted	Thermistor connected to drive is short circuit.
Charge Relay Fault	Internal bus charge relay has not closed.
Output Imbalance	Output current and/or voltage is out of balance.
DT V SC	Power Board Sizing Resistor is short circuit.
DT V OC	Power Board Sizing Resistor is open circuit.
DT A SC	Chassis Resistor is short circuit.
DT A OC	Chassis Resistor is open circuit.
DT BAD	Power Board and Chassis Resistor not compatible.
DT V BAD	Power Board and Chassis Resistor not compatible.
DT A BAD	Power Board and Chassis Resistor not compatible.

The following messages indicate operating modes and will not trip the VSC 2000.

Message	Meaning
CURRENT LIMIT	Motor is drawing maximum current.
BUS VOLTAGE HIGH	Motor is regenerating.
DC Braking	Drive is applying DC braking to the motor.
SCREEN LOCKED	Touch Screen will not respond to pressing.
Data Card missing	Data card is not plugged in & factory defaults are being used.
Data Card blank	No serial number exists on data card.
Data Card corrupt	Data is found to be corrupt.

VSC 2000 Trouble Shooting Guide

Symptom	Cause	Remedy
Power LED does not illuminate.	Input power wiring not connected properly. Input voltage not within specification.	Check input power wiring, refer to the VSC 2000 Electrical Installation Diagram. Measure the input voltage at the VSC 2000 input terminals. Check with specifications.
CCS does not illuminate.	No power to the CCS.	Check Power LED on control board is illuminated. Check CCS is connected to control board.
Motor does not rotate when FWD button on the CCS is pressed.	Enable signal is not active. VSC 2000 is in AUTO. Speed pot is set to minimum (anti clockwise).	Check that terminal 40 is connected to +24V (terminals 48 or 49) and that the green LED behind this terminal is illuminated. Press the MAN button on the CCS to enable local controls. Increase speed pot (clockwise).
Motor does not rotate when remote START signal is activated.	VSC 2000 is in MAN. Incorrect control signal wiring. Incorrect terminal strip selection. Enable signal is not active. Run signal is not active. A direction has not been selected. Speed signal is not correctly connected. Incorrect speed signal selected.	Press the AUTO button on the CCS to enable remote controls. Check control wiring to terminals 10 through 50. Refer to Control Wiring Diagram and Terminal Configurations. From <i>DRIVE CONFIG</i> menu press <i>TERMINAL SELECTION</i> and choose the appropriate terminal strip configuration. See Industrial/HVAC/Enhanced Terminal Configurations for terminal definitions. Check that terminal 40 is connected to +24V (terminals 48 or 49) and that the green LED behind this terminal is illuminated. For <i>INDUSTRIAL TERMINALS</i> and <i>HVAC TERMINALS</i> terminal 42 should be connected to +24V (terminals 48 or 49) and that the green LED behind this terminal is illuminated. For <i>ENHANCED TERMINALS</i> terminal 41 should be connected to +24V (terminals 48 or 49) and that the green LED behind this terminal is illuminated. Check that the Forward terminal is at +24V with respect to digital common (DIG COM). This is terminal 43 on <i>INDUSTRIAL TERMINALS</i> and <i>HVAC TERMINALS</i> . On <i>ENHANCED TERMINALS</i> this is 42. If Reverse is to be the chosen direction, then ensure that <i>REVERSE DIRECTION</i> is enabled from the CCS. Check wiring for terminals 11 & 12 if IN 1 is used as a speed reference input or terminals 14 & 15 if IN 2 is used. See Control Wiring Diagram. Choose the appropriate speed signal type from the <i>INPUT SELECTION</i> menu and ensure that the DIP switch settings are correct.
Motor does not accelerate in the time set by the ACCEL ramp and CURRENT LIMIT message appears on CCS.	Current limit circuit is operating. <i>CURRENT LIMIT</i> set to low.	This is a normal operating mode for the VSC 2000. If the extended acceleration time can be tolerated, then there is no need to make further adjustments. When the load is being accelerated too fast, the VSC 2000 limits current drawn by the motor by extending the acceleration ramp time. Increase <i>ACCEL</i> ramp time. Increase current limit value so that the VSC 2000 is not prematurely limiting current. Check that motor current rating is not exceeded.
CURRENT LIMIT message appears continuously on CCS.	Motor mechanically overloaded. Motor shaft jammed. Fault in motor or motor wiring. Incorrect motor voltage selected. Incorrect motor frequency selected. <i>AUTOMATIC BOOST</i> is set too high.	Check the actual load is within the motor's capacity at the required speed. Check the mechanical drive system. Check that motor is wired correctly. Enter correct motor voltage from the <i>MOTOR</i> menu. Enter correct motor frequency from the <i>MOTOR</i> menu. Reduce <i>AUTOMATIC BOOST</i> setting.
Motor does not accelerate in the time set by the ACCEL ramp.	Wrong ramp has been selected.	Check that ramp times for <i>RAMP 1</i> and <i>RAMP 2</i> are set correctly and that the appropriate ramp has been selected from the terminals strip. See Terminal Strip Configurations and Ramps in the manual.

VSC 2000 Trouble Shooting Guide (Cont.)

Symptom	Cause	Remedy
Motor does not decelerate in the time set by the <i>DECEL</i> ramp and VOLTAGE LIMIT message appears on CCS.	Voltage limit circuit is operating.	This is a normal operating mode for the VSC 2000. If the extended deceleration time can be tolerated, then there is no need to make further adjustments. When the load is being decelerated too fast, the VSC 2000 limits current regenerated by the motor by extending the deceleration ramp time. Increase <i>DECEL</i> ramp time. Select <i>DC BRAKE</i> from <i>DRIVE STOPPING</i> menu. Adjust strength and duration of braking from the <i>DC BRAKING</i> menu. Fit a dynamic braking module if controlled braking or maximum deceleration is required.
Motor does not decelerate in the time set by the <i>DECEL</i> ramp. VOLTAGE LIMIT message appears on CCS.	Wrong ramp has been selected. Input voltage has exceeded maximum rating.	Check that ramp times for <i>RAMP 1</i> and <i>RAMP 2</i> are set correctly and that the appropriate ramp has been selected from the terminals strip. See Terminal Strip Configurations and Ramps in the manual. See VSC 2000 General Specifications for input voltage ratings.
OVER CURRENT message appears on CCS.	Short circuit on motor terminals. Motor full load current is greater than 1.5 x drive rated current.	Check wiring to motor terminals. Check drive and motor current ratings.
OVER VOLTAGE message appears on CCS.	Input voltage has exceeded maximum ratings Motor is overhauling.	See general specification and check input is within ratings. If it is OK then restart the unit. Check input supply for voltage transients. Fix the external source. Ensure load cannot overdrive the motor. If necessary fit dynamic braking.
INTERNAL TOO HOT or HEATSINK TOO HOT message on CCS.	Ventilation problem. Drive is constantly overloaded.	Ensure operating ambient temperature is within specification. Check fans are rotating freely and there is no build up of dust or debris in blades. Visually examine the heatsink fins for build up of dust and debris. Reduce audible carrier frequency by selecting a lower carrier in the <i>AUDIBLE FREQUENCY</i> menu - choose 8.0kHz as a starting value and increase if HEATSINK TOO HOT trip is no longer occurring or decrease further if necessary.
Motor is unstable.	<i>SLIP COMP</i> is set too high. <i>AUTOMATIC BOOST</i> is set too high. Incorrect motor voltage selected. Incorrect motor frequency selected. <i>CURRENT LIMIT</i> is set too low.	Check that <i>MOTOR NAMEPLATE RPM</i> is equal to the motor rated speed. Check that <i>NAMEPLATE CURRENT</i> is equal to the motor rated speed. Reduce <i>SLIP COMP</i> setting. Reduce <i>AUTOMATIC BOOST</i> setting. Enter correct motor voltage from the <i>MOTOR</i> menu. Enter correct motor frequency from the <i>MOTOR</i> menu. Increase <i>CURRENT LIMIT</i> setting.
Excessive Motor Heating.	<i>AUTOMATIC BOOST</i> is high and motor is running at low speeds for long times. Motor damaged or incorrectly wired. Incorrect motor voltage selected. Incorrect motor frequency selected.	Do not run the motor at low speeds for long periods with <i>AUTOMATIC BOOST</i> set high, unless the motor has been suitably de-rated or is force cooled. Check the motor and motor wiring for faults. Enter correct motor voltage from the <i>MOTOR</i> menu. Enter correct motor frequency from the <i>MOTOR</i> menu.
Touch Screen does not respond.	Touch Screen has been locked.	Check that switch 1 of DIP switch SW1 on the back of the CCS (inside the door of the VSC 2000) is opened.
Touch Screen does not operate properly.	Touch Screen out of calibration	See the Touch Screen calibration procedure in the User's Manual.
Wrong language is displayed on the CCS.		See the User's Manual for menu structure diagram. Use it to navigate the menus to <i>LANGUAGE</i> - select the appropriate language.
Display is too dark or it is too light.	A change in temperature has occurred since the display was last adjusted.	Adjust the LCD contrast ratio from the <i>DISPLAY</i> menu.

**Australian
Manufacturers**

DELIVERY ADDRESS
366 Horsley Road
MILPERRA
NSW 2214
AUSTRALIA

ZENER ELECTRIC PTY LIMITED

ACN 001 595 428

POSTAL ADDRESS
P.O. Box 4462
MILPERRA DC
NSW 1891
AUSTRALIA

Tel: +61-2 - 9795 3600
Fax: +61-2 - 9795 3611
Email: zener@zener.net

