

# VSC-2000

## User Manual

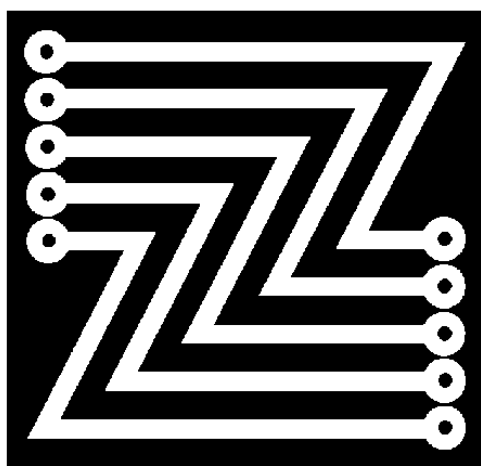

**ZENER**

# VSC 2000 User's Manual

## Table of contents

Section	Page
SAFETY WARNING.....	1
RECEIVING .....	1
FIRMWARE APPLICABLE.....	1
COMPREHENSIVE CONTROL STATION (CCS) OPERATION, DISABLING THE CCS TOUCH SCREEN.....	2
DATA ENTRY VIA THE CCS, LINEARISING THE CCS TOUCH SCREEN .....	2
START UP.....	3
USING THE MENU SYSTEM.....	3
CCS MENU - INDEX .....	4
SETUP.....	5
QUICK SETUP .....	5
COMPLETE SETUP .....	6
PID CONTROLLER.....	23
VSC 2000 COMMUNICATIONS .....	31

## Safety Warning

Your VSC 2000 must not be used as a safety device (especially in applications such as cranes and hoists). It must be applied, installed and operated in a safe manner. Zener Electric Pty. Ltd. denies all responsibility for damage and/or injuries caused by operating the VSC 2000 in a way that does not entirely conform to the above.

## Receiving

Inspect the VSC 2000 for shipping damage. If any damage is found, report it to the carrier immediately. Access the inside of the controller and check for any visually apparent damage.

**DO NOT ATTEMPT TO OPERATE THE VSC 2000 IF ANY OBVIOUS DAMAGE EXISTS.**

After the initial inspection, the VSC 2000 may be re-packed and stored in a clean dry location until you are ready to use it. DO NOT store this equipment in any area where the ambient temperature will rise above 70°C (158°F) or drop below -20°C (-4°F). DO NOT store this equipment in areas of high condensation or corrosive atmosphere.

## Firmware Applicable

New sections of this manual apply to firmware available from EPROM revisions released after 2 July, 1997.

Applicable to VSC 2000's with EPROM Part Numbers,

J930000M

J941000R

J942000H

### Comprehensive Control Station Operation (CCS)

The VSC 2000 is shipped with a Comprehensive Control Station (CCS) which allows all of its operating parameters to be fully customized in order to suit virtually any application, simple or complex. Figure 1 on the right shows the layout of the Comprehensive Control Station (CCS). Below is a description of the controls:

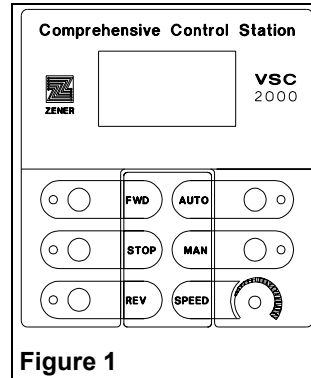

Figure 1

**AUTO:** Pressing this button will cause the adjacent yellow LED to illuminate and the VSC 2000 to be controlled remotely, via push-buttons, relay contacts or an external speed reference, which could be a potentiometer or another signal source connected to the terminal strip (see Control Wiring Diagrams in the VSC 2000 Installation Manual). The VSC 2000 defaults to this mode when power is applied if Auto has been selected in POWER ON MODE of the Complete Setup. See CCS IN AUTO for using the CCS SPEED pot while in AUTO mode.

**MAN:** Pressing this button enables the local controls (FWD, STOP, REV and the local speed potentiometer) and causes the adjacent yellow LED to illuminate.

**FWD:** Pressing this button causes the VSC 2000, if enabled, to run in the forward direction. The adjacent green LED illuminates to indicate that Forward has been selected (the LED flashing indicates that FWD has been selected but that the motor is not yet going in the forward direction).

**REV:** Pressing this causes the VSC 2000, if enabled, to run in the reverse direction. The adjacent green LED illuminates to indicate that Reverse has been selected (the LED flashing indicates that REV has been selected but that the motor is not yet going in the reverse direction). The VSC 2000 is shipped with reverse direction disabled for safety reasons (see REVERSE DIRECTION page 8 for information on how to enable it).

**STOP:** Pressing this button will cause the VSC 2000 to stop when it is running (see also DRIVE STOPPING on page 17). If a trip condition occurs pressing the STOP button will clear it.

**SPEED:** This is the local potentiometer and it is used to set the desired speed when using local controls. Rotating the knob clockwise will increase the speed and counter-clockwise will decrease it.

### Disabling the CCS Touch Screen

To disable the touch screen use the switch SW1 at the back of the CCS printed circuit board. Move SW1:1 to the ON position. Do not change SW1:2 which is for setting terminating resistors on the CCS serial link.

### Data Entry via the CCS

The Comprehensive Control Station (CCS) permits the user to customize the VSC 2000 to a particular application. Full programming of the inverter is allowed through the use of the touch sensitive graphic display. When first powered up, the VSC 2000 displays the Zener logo and the versions of each of 3 EPROMs installed in the VSC 2000. It then displays the Run Screen, as shown in figure 2.

The entire screen is touch sensitive. To program the VSC 2000 or set parameters such as Maximum Speed, Motor Frequency, etc., first press your finger on top of the rectangle where Setup is displayed (Do not use sharp objects as they may scratch the screen cover). This will take you to the first setup screen which is the first page of menu items.

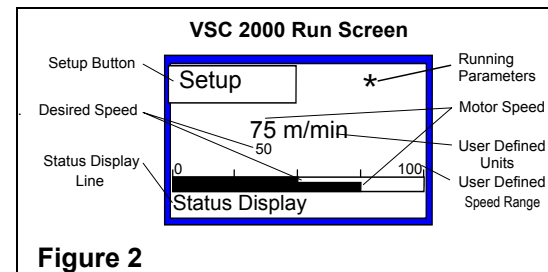

Figure 2

If you press the area to the right of the screen next to **Setup** where the ★ symbol is located, meter readout parameters such as frequency, output current, DC bus voltage, kW electrical output and % load will be displayed.

Follow the procedure below to start the VSC 2000. For a description of how to use the menus, set various parameters and enter data into the VSC 2000 refer to the following pages.

**NOTE:** the Touch Screen can be disabled at any time by setting switch 1 on the back of the CCS to the OFF position. The remaining CCS front panel push-buttons and the Speed potentiometer continue to operate

### Linearising the CCS Touch Screen

Linearising the CCS Touch Screen is necessary if the screen does not respond accurately i.e. it is difficult to make a selection between adjacent choices. To linearise the screen the power must be removed and reapplied to the CCS while holding down the Stop and Manual buttons simultaneously. A simple way to remove power from the CCS is to unplug it from the control board by opening the VSC 2000 front door and removing the flat cable connector from the rear of the CCS circuit board.

Hold down the STOP and MANUAL buttons and re-insert the cable plug. The CCS screen will power-up and you will see a small dot on the screen. Press exactly on this dot and another dot will appear. Press exactly over this dot again and so on until all dots are pressed and the screen automatically restores itself. The screen is now linearised.

## Start Up

Before proceeding with this section, it is assumed that you have read and understood the **VSC 2000 Installation Manual** Start-Up, and Adjustment Procedures and that Electrical Installation and the Control Wiring (if used) diagrams have been followed in making the installation. If not, then please refer to these sections now.

Switch on input power to the drive. The graphic display will illuminate and the LED's next to the buttons will flash once. If not, refer to the Trouble Shooting guide. With the MAN (manual) mode selected and the speed signal at zero, select a direction by pressing FWD or REV. The respective LED will illuminate. If it does not, or if any fault message is displayed, refer to the Trouble Shooting guide in the **VSC 2000 Installation Guide**.

If the motor shaft spins in the wrong direction, press STOP to activate the stop circuit, remove input power and swap any two motor phase wires. Re-apply input power and select a direction by pressing FWD or REV. Increase the speed signal to a maximum. The motor will accelerate smoothly to full speed. If not, refer to the Trouble Shooting guide in the **VSC 2000 Installation Guide**.

## Using the Menu System

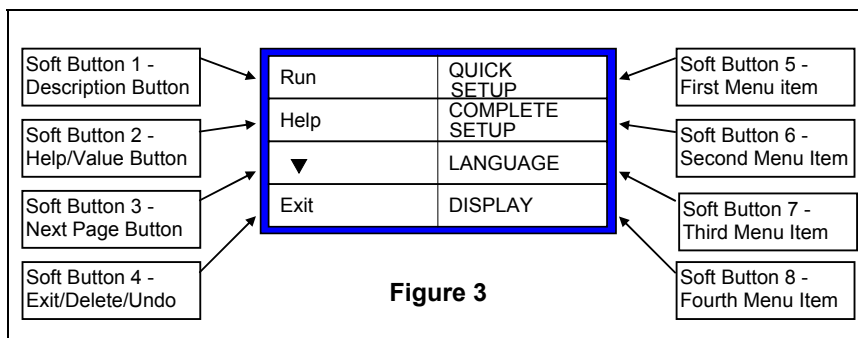

Figure 3 shows the first page of the menu system. Most menu pages are divided into eight rectangles which function like push-buttons. These buttons have different functions depending on what page of the menu you are in, and are referred to as "Soft Buttons." Some of these buttons (see below), will have the same function on all pages of the menu system on which they are displayed. Below is a description of buttons common to most menu screens:

- **Description Button:**

This button displays "Run" or the name of the menu item that has been selected. When Run is displayed, pressing this button will take you back to the running screen (figure 2). Pressing Setup again will bring you back to where you were before Run was pressed. Whenever Run is not displayed, pressing this button will save any changes in selections that have just been made and jump back to the previous menu screen;

- **Help Button:**

Pressing this button will display a context dependent Help message;

- **'Value' Button:**

Soft Button 2 is also used to hold the present value of multiple selection parameters. For example, when setting Maximum Speed, the Value Button will display the present value for maximum speed until it is changed. Note: If Help is not the current display, this button functions only to display values, pressing a Value button causes no action to be performed.

- **Previous Page (▲) Button:**

Appears in place of the Help Button when there are more than four menu items to choose from. Pressing this button will cycle backwards through all pages of menu items available;

- **Next Page (▼) Button:**

Appears when there are more than four menu items to choose from. Pressing this button will cycle forward through all pages of menu items;

- **Exit Button:**

Saves all the information entered and jumps back to the previous screen. The only difference between the exit button and the run button (Description button with Run displayed) is that pressing Run will always jump to the Run screen;

- **Delete (◀) Button:**

When this button is displayed, pressing it will cause the cursor to move to the left deleting whatever character is displayed (destructive backspace);

- **Undo Button:**

When this button is displayed, pressing it will cancel the last selection. Applies to entering alpha-numeric characters.

CCS Menu - Index

Feature	Page	Feature	Page	Feature	Page
<b>QUICK SETUP .....</b>	<b>5</b>	▶▶ POWER ON SCREEN.....	14	▶ PID CONTROLLER.....	19
▶ MOTOR .....	5	▶ CCS IN AUTO .....	14	▶ TACHO FEEDBACK.....	20
▶▶ MOTOR VOLTAGE .....	5	▶ DISPLAY UNITS .....	14	<b>DISPLAY .....</b>	<b>20</b>
▶▶ NAMEPLATE CURRENT .....	5	▶ DISPLAY SCALE .....	14	▶ DARKER .....	20
▶▶ MOTOR FREQUENCY.....	5	▶ SLIP COMP .....	14	▶ LIGHTER.....	20
▶▶ NAMEPLATE SPEED RPM.....	5	▶ START DELAY.....	14	▶ SERIAL NUMBER .....	20
▶ RAMP .....	6	▶ AUTO RESTART.....	15	<b>LANGUAGE .....</b>	<b>20</b>
▶ MINIMUM FREQUENCY.....	6	▶▶ NUMBER OF RESTARTS.....	15	<b>METER READOUTS .....</b>	<b>20</b>
▶ MAXIMUM FREQUENCY.....	6	▶▶ RESET TIME .....	15	<b>SERVICE.....</b>	<b>20</b>
<b>COMPLETE SETUP .....</b>	<b>6</b>	▶▶ ENABLE / DISABLE .....	15	▶ FAN CONTROL.....	21
▶ MOTOR .....	7	▶ POWER FAIL TRIP RESET .....	15	▶▶ INTERNAL FAN .....	21
▶ RAMP .....	7	▶ PRESET SPEEDS .....	15	▶▶ HEATSINK FAN .....	21
▶▶ RAMP 1, ▶▶ RAMP 2.....	7	▶▶ PRESET 1.....	15	▶ PHASE FAILURE TRIP .....	21
▶ MINIMUM FREQUENCY.....	8	▶▶ PRESET 2, 3, 4, 5 & 6.....	15	▶ POWER FAILURE TRIP.....	21
▶ MAXIMUM FREQUENCY.....	8	▶ SKIP SPEEDS.....	15	▶ IMBALANCE TRIP .....	21
▶ REVERSE DIRECTION.....	8	▶▶ SKIP 1 .....	16	<b>THERMAL DISPLAY.....</b>	<b>21</b>
▶ CURRENT LIMIT.....	8	▶▶ SKIP 2, 3 & 4 .....	16	<b>RUN LOG .....</b>	<b>21</b>
▶ THERMAL PROTECTION.....	8	▶ JOG .....	16	<b>TRIP LOG.....</b>	<b>21</b>
▶▶ THERMAL TRIP .....	9	▶▶ SPEED SOURCE.....	16	▶ DISPLAY .....	21
▶▶ THERMAL DEVICE .....	9	▶ ESSENTIAL SERVICES.....	16	▶ PF / UV MASK.....	22
▶▶ I <sup>2</sup> T PROTECTION .....	9	▶▶ ENABLE, ▶▶ DISABLE.....	17	▶ CLEAR .....	22
▶ AUTOMATIC BOOST.....	9	▶▶ TIME ENABLED .....	17	▶ DATE.....	22
▶ DRIVE CONFIG .....	9	▶▶ TIME STRESSED .....	17	▶ TIME.....	22
▶▶ SELECT TERMINALS.....	9	▶ AUDIBLE FREQUENCY.....	17	<b>RS-485 SETUP.....</b>	<b>22</b>
▶▶ SET CUSTOM DEFAULTS .....	10	▶ DRIVE STOPPING .....	17	▶ DRIVE ID NUMBER .....	22
▶▶ RESTORE DEFAULTS .....	10	▶▶ RAMP.....	18	▶ BIT RATE .....	22
▶ ANALOG INPUTS .....	10	▶▶ COAST.....	18	▶ DATA FORMAT.....	22
▶▶ INPUT 1.....	10	▶▶ DC BRAKE .....	18	▶ 2/4 WIRE .....	22
▶▶ INPUT 2.....	11	▶ DC BRAKING .....	18	<b>FACTORY CONTROLS .....</b>	<b>22</b>
▶ ANALOG OUTPUTS .....	11	▶ DYNAMIC BRAKING.....	18	<b>PID CONTROLLER.....</b>	<b>23</b>
▶▶ ANALOG OUTPUT 1.....	12	SELECTING THE BRAKING RESISTOR .....	18	<b>VSC 2000 COMMUNICATIONS.....</b>	<b>31</b>
▶▶ ANALOG OUTPUT 2.....	12	INSTALLING THE BRAKING RESISTOR.....	19		
▶ DIGITAL OUTPUTS .....	13	ENABLING DYNAMIC BRAKING .....	19		
▶▶ RELAY 2.....	13	▶ MOTORIZED POT .....	19		
▶▶ OUTPUTS J, K, L & M.....	13	▶▶ DISABLE .....	19		
▶ POWER ON CONFIG .....	13	▶▶ PERSISTENT MODE.....	19		
▶▶ POWER ON MODE.....	13	▶▶ RESET MODE.....	19		
		▶▶ PRELOAD .....	19		

**Setup**

Feature	Page
<b>AVAILABLE CHOICES:</b> QUICK SETUP .....	5
COMPLETE SETUP .....	6
DISPLAY .....	20
LANGUAGE .....	20
METER READOUTS.....	20
SERVICE .....	20
THERMAL DISPLAY .....	21
RUN LOG .....	21
TRIP LOG .....	21
RS-485 SETUP .....	22
FACTORY CONTROLS .....	22

Pressing **Setup** in the Run Screen provides access to all of the features of the VSC 2000 via the first level screen shown in Figure 4. The application you have for the VSC 2000 may allow you to run the inverter using the Factory Defaults, or you might want to change some parameters. The CCS Menu Index above can be helpful if any additional features for customizing the performance of the inverter are needed. Pressing QUICK SETUP will take into this menu. COMPLETE SETUP will take you into the extensive set up menu.

**Figure 4:** The first level CCS Menu

Run	QUICK SETUP
Help	COMPLETE SETUP
▼	LANGUAGE
Exit	DISPLAY

Screen obtained by pressing

**QUICK SETUP**

- Available Choices:** MOTOR  
 RAMP  
 MINIMUM FREQUENCY  
 MAXIMUM FREQUENCY

**▶ MOTOR**

- Available Choices:** MOTOR VOLTAGE  
 NAMEPLATE CURRENT  
 MOTOR FREQUENCY  
 NAMEPLATE SPEED RPM

This menu allows you to enter specific information about the motor that you are using. For improved performance see MOTOR on the COMPLETE SETUP.

To exit the Motor menu press the Exit button (or the Run button to jump to the running screen).

**▶▶ MOTOR VOLTAGE**

**Available Choices:** 330, 380, 415 V  
 440, 460, 480 V - these are choices for VSC 2G's only.

Custom .....range:

Model	Voltage Range
VSC2A	200 - 240
VSC2G	330 - 480
VSC2J	330 - 600

Select a voltage value equal to the nameplate voltage of your motor. Press the ▼ button to see more choices or to enter the desired value using Custom. Press MOTOR VOLTAGE or Exit button to exit.

**▶▶ NAMEPLATE CURRENT**

**Available Choices:** Enter Value

Enter the value equal to the Nameplate Current on your motor. This will determine the operation points for I<sup>2</sup>t Protection and the LOAD Signal Source for the Analog Output. Note that this setting cannot be used to limit the output current of the VSC 2000. Refer to ▶ CURRENT LIMIT for that particular feature. Press the NAMEPLATE CURRENT button to save and exit the changes or the Cancel button to just exit Nameplate Current.

**▶▶ MOTOR FREQUENCY**

**Available Choices:** 50Hz, 60Hz  
 Custom..... (range: 40Hz to 120Hz)

Select 50Hz or 60Hz depending on the nameplate frequency of your motor. Note that this setting cannot be used to set or limit the frequency output of the VSC 2000. Refer to MINIMUM/MAXIMUM FREQUENCY for that particular feature.

Press the MOTOR FREQUENCY button or the Exit button to exit Motor Frequency.

**▶▶ NAMEPLATE SPEED RPM**

**Available Choices:** Enter Value

Enter the rated motor speed according to the nameplate of your motor. Note that this setting cannot be used to set or limit the output speed of the VSC 2000.

Press the NAMEPLATE SPEED RPM button to save changes and exit Nameplate Speed.

**▶ RAMP**

**Available Choices:** 5, 10, 30 seconds  
 Custom..... (range: 0.5 to 600 seconds)

This Ramp setting allows you to set a single linear ramp time for acceleration and deceleration, and it overwrites the linear settings of Ramp 1 in the Complete Setup (see RAMP under COMPLETE SETUP for independent linear and S-curve ramps).

The value entered is the time that the output frequency of the VSC 2000 will take to go from zero speed up to motor rated speed (50 or 60Hz). On a 50Hz drive, this means that if the ramp time is set to 10 seconds and maximum speed is set to 75Hz, then the VSC 2000 will take 10 seconds to go from 0 to 50Hz and another 5 seconds to go from 50Hz to 75Hz, or 15 seconds from 0 to 75Hz. Select the ramp time from the available choices or enter the desired value using Custom.

Press the RAMP button or the Exit button to save any changes and exit Ramp.

**▶ MINIMUM FREQUENCY**

**Available Choices:** Custom..... (range: 0 to Maximum Frequency minus 5Hz)

This sets the lowest frequency that the VSC 2000 will run at every time it is enabled and a direction is selected. The largest value for Minimum Frequency is always limited to be 5Hz below the current setting for Maximum Frequency. For example, if Maximum Frequency is set to 45Hz, then the largest allowed value for Minimum Frequency is 40Hz. Enter the desired value for Minimum Frequency using the numerical entry screen.

To save the changes and exit Minimum Frequency press the MINIMUM FREQUENCY button.

**▶ MAXIMUM FREQUENCY**

**Available Choices:** 50, 75, 100Hz  
 60, 90, 120Hz  
 Custom...(range: Minimum Speed setting plus 5Hz up to 200Hz)

The VSC 2000 can be set to run a 50Hz or 60 Hz motor from 0 up to 200Hz. Choose the maximum frequency by pressing the appropriate button or enter the desired value using Custom. This setting can also be used to limit the output frequency of the VSC 2000 to just about any value within the range. The lowest value for the Maximum Frequency is limited to be 5 Hz above the current Minimum Frequency setting (e.g. If Minimum Speed setting is 5Hz then the lowest value allowed for Maximum Speed is 10Hz).

**COMPLETE SETUP**

Feature	Page
<b>Available Choices:</b> ▶ MOTOR .....	5
▶ RAMP .....	6
▶ MINIMUM FREQUENCY .....	6
▶ MAXIMUM FREQUENCY .....	6
▶ MOTOR.....	7
▶ RAMP .....	7
▶ MINIMUM FREQUENCY .....	8
▶ MAXIMUM FREQUENCY .....	8
▶ REVERSE DIRECTION .....	8
▶ CURRENT LIMIT .....	8
▶ THERMAL PROTECTION .....	8
▶ AUTOMATIC BOOST .....	9
▶ DRIVE CONFIG .....	9
▶ ANALOG INPUTS .....	10
▶ ANALOG OUTPUTS .....	11
▶ DIGITAL OUTPUTS .....	13
▶ POWER ON CONFIG .....	13
▶ CCS IN AUTO .....	14
▶ DISPLAY UNITS .....	14
▶ DISPLAY SCALE .....	14
▶ SLIP COMP .....	14
▶ START DELAY .....	14
▶ AUTO RESTART .....	15
▶ POWER FAIL TRIP RESET .....	15
▶ PRESET SPEEDS .....	15
▶ SKIP SPEEDS .....	15
▶ JOG .....	16
▶ ESSENTIAL SERVICES .....	16
▶ AUDIBLE FREQUENCY .....	17
▶ DRIVE STOPPING .....	17
▶ DC BRAKING .....	18
▶ DYNAMIC BRAKING .....	18
▶ MOTORIZED POT .....	19
▶ PID CONTROLLER .....	19
▶ TACHO FEEDBACK .....	20

This menu allows the user to fine tune the VSC 2000 to any specific application. It also provides access to a number of special features that are only available through the Comprehensive Control Station. Press the Exit button to exit the Complete menu (or the Run button to jump to the Running Screen).

**MOTOR**

- Available Choices:** MOTOR VOLTAGE  
 NAMEPLATE CURRENT  
 MOTOR FREQUENCY  
 NAMEPLATE SPEED RPM

Similarly to the MOTOR menu in Quick Setup, this menu allows you to enter specific information about the motor that you are using, so as to obtain an increased performance. Several advanced features of the VSC 2000 have some of their parameters derived from the information that you enter here. Follow the instructions below in order to set each parameter.

**NOTE:** The factory defaults for the MOTOR parameters are based on values for typical motors whose size is matched to that of the inverter (same ratings as the drive) and therefore do not need to be changed. Changing these parameters is of particular importance if a better dynamic performance of the drive is required (as in high starting torque requirement applications) or when you are using a motor whose rating is different to that of your inverter.

**RAMP**

- Available Choices:** RAMP 1  
 RAMP 2

The VSC 2000 has two independently programmable Ramps each with settable acceleration and deceleration rates which can be linear or S-curves. Individual settings are provided for the linear and curved portions of each ramp. It is possible to change between Ramp 1 and Ramp 2 rates while the drive is operating via an external signal to Ramp1/Ramp2, Control Input B, in Enhanced Terminal Configuration. This allows for two acceleration rates which could be selected by the At Speed flag set as a Digital Output for example. See DIGITAL OUTPUT.

**RAMP 1, RAMP 2**

- Available Choices:** ACCEL TIME  
 ACCEL S TIME  
 DECEL TIME  
 DECEL S TIME

The VSC 2000 defaults to using Ramp 1 every time power is applied. The following descriptions apply to both Ramp 1 and Ramp 2. When acceleration of the motor and load is required, the ACCEL TIME and ACCEL S TIME settings are used. When deceleration of the motor and load is required, the DECEL TIME and DECEL S TIME settings are used.

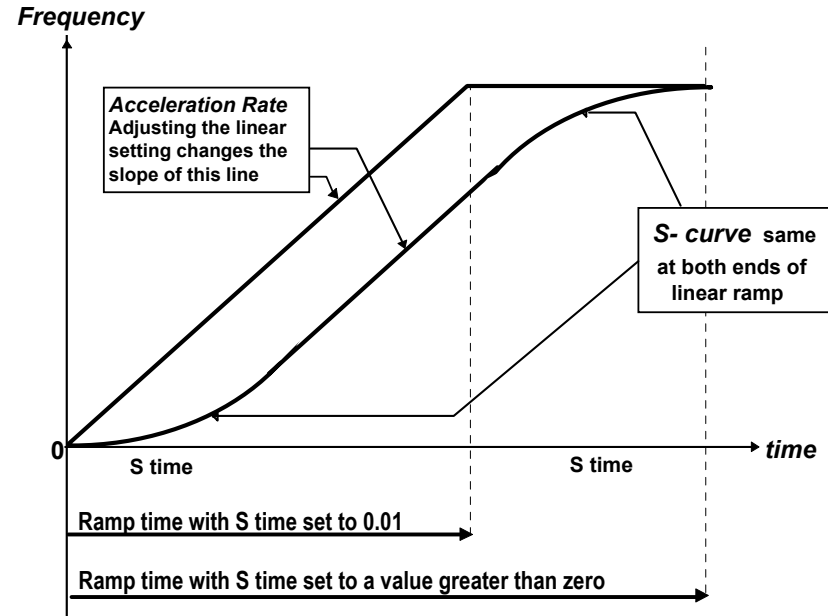

**ACCEL TIME**

- Available Choices:** 1, 2, 5 sec  
 15, 30, 60, 120 sec  
 Custom ..... (range: 0.5 to 600 seconds)

The ACCEL TIME is the time taken for the rotor to go from zero speed up to motor rated speed. On a 50Hz drive, this means that if the ramp time is set to 10 seconds and maximum speed is set to 75Hz, then the VSC 2000 will take 10 seconds to go from 0 to 50Hz and another 5 seconds to go from 50Hz to 75Hz (15 seconds from 0 to 75Hz), if ACCEL S TIME is set to minimum.

**ACCEL S TIME**

- Available Choices:** 1, 5, 15 sec  
 Custom ..... (range: 0.01 to 40 seconds)

The ACCEL S TIME is the time taken for the rotor acceleration to reach the limit of acceleration (as set by the rated speed and the ACCEL TIME). Using the Accel S Time ensures smooth speed increases when accelerating. The longer the Accel S Time, the smoother the speed increase.

The Accel S Time is added to the beginning and to the end of the linear ramp, which means that the Accel or Decel time from 0 to 50Hz is roughly equal to twice the S-curve time plus the linear time. The actual calculation of the S-curve is a parabolic function so true Accel Time is not precisely determined by the above.

**DECEL TIME**

**Available Choices:** 1 sec, 2 sec, 5 sec  
 15, 30, 60, 120 sec  
 Custom..... (range: 0.5 to 600 seconds)

The DECEL TIME is the time taken for the rotor to go from motor rated speed down to zero speed (assuming minimum Decel S Time). On a 50Hz drive, this means that, if the ramp time is set to 10 seconds and maximum speed is set to 75Hz, then the VSC 2000 will take 5 seconds to go from 75Hz down to 50Hz and another 10 seconds to go from 50Hz down to 0.

**DECEL S TIME**

**Available Choices:** 1, 5, 15 sec  
 Custom..... (range: 0.01 to 40 seconds)

The DECEL S TIME is the time taken for the rotor deceleration to reach the limit of deceleration (as set by the rated speed and the Decel Time). The Decel S Time is added to the beginning and to the end of the linear ramp, which means that the Decel Time from 50 to 0Hz is roughly equal to twice the S-curve time plus the linear time. The calculation of the S-curve is actually a parabolic function so the Decel time is not precisely determined by the above.

**MINIMUM FREQUENCY**

**Available Choices:** Custom..... (range: 0 to Maximum Frequency minus 5Hz)

This sets the lowest frequency that the VSC 2000 will run at every time it is enabled and a direction is selected. The largest value for Minimum Frequency is always limited to be 5Hz below the current setting for Maximum Frequency. For example, if Maximum Frequency is set to 45Hz, then the largest allowed value for Minimum Frequency is 40Hz. Enter the desired value for Minimum Frequency using the numerical screen.

To save the changes and exit Minimum Frequency press the MINIMUM FREQUENCY button.

**MAXIMUM FREQUENCY**

**Available Choices:** 50, 75, 100Hz  
 60, 90, 120Hz  
 Custom.....(range: Min. Speed setting + 5Hz up to 200Hz)

The VSC 2000 can be set to run a 50Hz or 60Hz motor up to 200Hz. Choose the maximum frequency by pressing the appropriate button or enter the desired value using Custom. This setting can also be used to limit the output frequency of the VSC 2000 to just about any value within the range. The lowest value for the Maximum Speed is limited to be 5 Hz above the current Minimum Speed setting (e.g. If Minimum Speed setting = 5Hz then the lowest value allowed for Maximum Speed is 10Hz).

To save the value and exit Maximum Frequency press the MAXIMUM FREQUENCY button or the Exit button.

**REVERSE DIRECTION**

**Available Choices:** ENABLE  
 DISABLE

The VSC 2000 is shipped with Reverse Direction Disabled in order to avoid possible mechanical damage to gearboxes or other drive equipment caused by the motor running backwards. Enable Reverse Direction by pressing the appropriate button.

To save the changes and exit Reverse Direction press the REVERSE DIRECTION button or the Exit button.

**CURRENT LIMIT**

**Available Choices:** 75%  
 110%  
 Custom ..... (Range is model dependent - see below)

This sets the maximum output current of the VSC 2000 as a percentage of the VSC 2000's rated current. To change the limiting point select from the choices available or enter the desired value by using Custom. This setting is not effected by the value entered for Namplate Current. Note: Current limiting is achieved by reducing the speed of the motor, i.e. by reducing output frequency.

VSC 2000 Model	Current Limit Range
VSC-2A---, VSC-2G---, VSC-2J--- General Purpose Drives	36% to 110%

**THERMAL PROTECTION**

**Available Choices:** THERMAL TRIP  
 THERMAL DEVICE  
 I<sup>2</sup>t PROTECTION

An input is provided on the Control board Analog terminal strip for direct connection of a sensing device to be used for external thermal protection of the motor. Connection details are shown in the **VSC 2000 Installation Manual** 'VSC 2000 Control Wiring Diagrams'. Note that it is allowed to enable both an external sensing device and I<sup>2</sup>t protection.

◆◆ **THERMAL TRIP**

**Available Choices:** ENABLE  
DISABLE

Enables or Disables the Thermal Protection input of the VSC 2000. Thermal Trip should be disabled if there is no thermistor or thermal switch connected.

To save the changes and exit Thermal Trip press the THERMAL TRIP button or the Exit button.

◆◆ **THERMAL DEVICE**

**Available Choices:** THERMISTOR  
MICROTHERM

Select the thermal protection device is being used from either a Thermistor; or a Microtherm (thermal switch). Press over the device name to select it. The VSC 2000 will detect a shorted thermistor.

To save the changes and exit Thermal Device press the THERMAL DEVICE button or the Exit button.

◆◆ **I<sup>2</sup>t PROTECTION**

**Available Choices:** ENABLE  
DISABLE  
I<sup>2</sup>t: Enter Value ..... (range: 36 to 150% of  
Motor Nameplate Current)

The I<sup>2</sup>t value is set to match the motor automatically when the motor Nameplate Current is entered under MOTOR parameters in COMPLETE SETUP. The drive will trip on I<sup>2</sup>t after the motor has been running at 110% motor Nameplate Current for approximately two minutes. I<sup>2</sup>t is not suitable for multiple motors running on one VSC 2000 since there is no discrimination between individual motors. NOTE: If power is removed from the drive after an I<sup>2</sup>t trip, the motor should be allowed to cool down before the inverter is restarted. Motors running highly loaded at low speeds should have external cooling and an external motor thermal sensing device such as microtherms or thermistors for protection.

To save the changes and exit I<sup>2</sup>t Protection press the I<sup>2</sup>t PROTECTION button or the Exit button.

◆ **AUTOMATIC BOOST**

**Available Choices:** Enter Value (range: 0 to 150%)

This feature controls the amount of compensation applied to the motor flux vector to account for the effects of motor stator resistance. At low speeds motor stator resistance is most significant and accounts for a large portion of voltage drop in the applied motor voltage Automatic Boost minimizes these losses of magnetising at low speeds and ensures flux levels produce the correct amount of torque. Increasing Automatic Boost increases the output torque. This applies across the entire speed range but is most noticeable at low speeds.

The VSC 2000 estimates the stator resistance from the given motor parameters and uses these to optimise performance. Automatic Boost, when correctly adjusted ensures a constant flux level at low speeds and allows the motor to develop the necessary torque in this region. In addition, correct adjustment of this control is necessary to achieve an accurate load signal over a wide speed range.

The default value setting of 25% Automatic Boost is a good starting point for normal applications will provide optimum torque and the best possible Load Output Signal for many applications particularly where the load is a fan, with low torque requirement at start up. For a high torque application Automatic Boost set to 100% will allow greater torque however, some care should be exercised when adjusting boost because too much boost may cause some motor instability.

◆ **DRIVE CONFIG**

**Available Choices:** SELECT TERMINALS  
SET CUSTOM DEFAULTS  
RESTORE DEFAULTS

This facility allows you to select the terminal configuration of the control input and outputs of the VSC 2000. Options are; HVAC, Industrial or Enhanced Terminals. The terminal configurations are described in detail in the VSC 2000 Installation Manual. Drive Config is also where you can restore the factory defaults for all of the settings of the VSC 2000

◆◆ **SELECT TERMINALS**

Select the control terminal configuration you require from:

**INDUSTRIAL TERMINALS**

This is the factory default setting.

**HVAC TERMINALS**

Used for Air Conditioning applications, includes the Essential Services Override feature.

**ENHANCED TERMINALS**

An Extended Features board is required to fully utilize this terminal strip configuration, with 6 Preset Speeds to choose from, Motorized Pot and Ramp 1 or 2 select available.

◆◆ **SET CUSTOM DEFAULTS**

Replace user settings with factory default values for the current terminal selection. For the terminal strip selected a set of factory parameters are loaded.

◆◆ **RESTORE DEFAULTS**

Reload entire controller parameters and factory defaults for Industrial Terminals. Replaces user settings and initialises controller parameters independent of terminal selection.

◆ **ANALOG INPUTS**

**Available Choices:** INPUT 1  
INPUT 2

The VSC 2000 provides two Analog Inputs which can be programmed to receive current signals (0 to 20mA or 4 to 20mA) or voltage signals (0 to 5Vdc or 0 to 10Vdc). Select each of the inputs from the available choices and set it up according to the descriptions below.

To select Input 1 or Input 2 as a speed reference in your installation of the VSC 2000 use the Control Input terminals (inputs G and H, and F -for Enhanced Terminals) to select the Speed reference. Refer to the **VSC 2000 Installation Manual** Terminal Configurations tables for details. For example to select Input 2 (IN 2), input G must be taken *high* , otherwise the default is Input 1.

To save the changes and exit Analog Input press the ANALOG INPUT button or the Exit button.

◆◆ **INPUT 1**

**Available Choices:** SIGNAL TYPE  
MINIMUM  
MAXIMUM  
SIGNAL CONDITION

This input is selected by default, which means that the VSC 2000 will look for a signal at this input when AUTO mode is selected on the CCS -unless Control Terminal inputs have been wired for a different Speed Reference (see above paragraphs). Minimum and Maximum values can be set for the analog inputs such that an input signal less than Minimum causes the VSC 2000 to run at Minimum Frequency and an input signal greater than Maximum causes it to run at Maximum Frequency.

The allowable operating range (Maximum-Minimum) is 10% of the value for the highest input signal (i.e. for a 0 to 5V DC input signal the lowest effective signal range is at 0.5V DC and the uppermost is 4.5V DC). Note that speed reference is linear between Minimum and Maximum points. Note also that the Minimum and Maximum values are completely independent from one another and do not affect the minimum and maximum speeds of the inverter.

To save the changes and exit Input 1 press the INPUT 1 button or the Exit button.

**SIGNAL TYPE**

**Available Choices:** 0 - 5V  
0 - 10V  
0 - 20mA  
4 - 20mA

This selects the required range for the analog input. A message will be displayed showing how the DIP switches on block SW1(located above the ANALOG input terminals) must be set on the Control Board of the VSC 2000. Make note of the switch positions so that they can be set accordingly *after the power has been removed and the capacitors are fully discharged*. As the two analog inputs are independent their switch settings are also independent. In the table below SW1-1 and SW1-2 apply only to Analog Input 1. SW1-3 and SW1-4 apply only to Analog Input 2. Therefore different ranges may be selected for each input and the appropriate switch settings will be on different lines in the table.

Type	Input 1		Input 2	
	SW 1-1	SW 1-2	SW 1-3	SW 1-4
<b>0-5V</b>	Open (OFF)	Open (OFF)	Open (OFF)	Open (OFF)
<b>0-10V</b>	Open (OFF)	Closed (ON)	Open (OFF)	Closed (ON)
<b>0-20mA</b>	Closed (ON)	Open (OFF)	Closed (ON)	Open (OFF)
<b>4-20mA</b>	Closed (ON)	Open (OFF)	Closed (ON)	Open (OFF)

**MINIMUM**

**Available Choices:** PRESENT VALUE

Custom ..... (range: depends on the Signal Type selected - see above)

To set the Minimum input value enter it using Custom (as Volts or mAmps, depending on the Signal Type selected) or press Present Value to have the VSC 2000 read the input and set the parameter to a value equal to the signal presently available at the input. An input signal equal to or less than this minimum value will cause the drive to run at minimum frequency.

To save the changes and exit Minimum press the MINIMUM button or the Exit button.

### MAXIMUM

**Available Choices:** PRESENT VALUE  
Custom .....(range: depends on the  
Signal Type selected - see above)

To set the Maximum input value enter it using Custom (as Volts or mAmps, depending on the Signal Type selected) or press Present Value to have the VSC 2000 read the input and set the parameter to a value equal to the signal presently available at the input. An input signal equal to or greater than this maximum value will cause the drive to run at maximum frequency. The speed reference is linear between the minimum and maximum values. The maximum range on the analog input is 10% of the selected range (i.e. 0.5 V for a 0 - 5 V range). These minimum and maximum values are independent of the drives minimum and maximum frequencies.

### SIGNAL CONDITION

**Available Choices:** REVERSE ACTING  
BIPOLAR SIGNAL

The two inputs can be independently set to operate in a Reverse Acting or Bipolar function. Reverse Acting means that a minimum input signal will cause the VSC 2000 to run at a Maximum Speed and a maximum input signal will cause it to run at Minimum Speed. A Bipolar Signal allows the VSC 2000 to be controlled in forward or reverse direction with a continuous input signal that passes through a leve.

To save the changes and exit Signal Condition press the SIGNAL CONDITION button or the Exit button.

### REVERSE ACTING

**Available Choices:** ENABLE  
DISABLE

The VSC 2000 is shipped with Reverse Acting Input Signal disabled. Enable it by pressing the appropriate button. When Reverse Acting is enabled, a minimum input signal will cause the VSC 2000 to run at Maximum Speed and a maximum input signal will cause it to run at Minimum Speed.

To save the changes and exit Reverse Acting press the REVERSE ACTING button or the Exit button.

### BIPOLAR SIGNAL

**Available Choices:** ENABLE  
DISABLE

This feature operates in a way that an analog input value in the middle of the selected range causes the VSC 2000 to stay at zero speed e.g. 2.5V for a 0 to 5V range, or  $[\text{Max.} + \text{Min}] / 2$  when minimum and maximum values have been set. An input of Maximum causes it to run at Maximum Speed in the Forward direction and

an input of Minimum causes it to run at Maximum Speed in the Reverse direction. Enable Bipolar Signal by pressing the Enable button.

Please note the following:

- Analog Input Minimum and Maximum still operational;
- Reverse Acting Input Signal still operational;
- This feature can only be accessed from Industrial Terminals
- The Run/Stop, Forward and Reverse inputs must be held high (connected to +24Vdc) for the VSC 2000 to run. See Industrial Terminals Configuration in the VSC 2000 Installation Manual;
- Reverse Direction must be enabled.

To save the changes and exit Bipolar Signal press the BIPOLAR SIGNAL button or the Exit button.

### ◆◆ INPUT 2

This input is selected by the Control Terminals input G set *high*. See **VSC 2000 Installation Manual** Terminal Configurations, Speed Reference table for details. In all other respects see INPUT 1 above.

### ◆ ANALOG OUTPUTS

**Available Choices:** ANALOG OUTPUT 1  
ANALOG OUTPUT 2

The VSC 2000 provides two independent analog outputs (**NOTE: Analog Output 2 is only available when the Extended Features board is installed**). The analog outputs are isolated to ensure improved electrical noise immunity and can be selected to indicate signals such as speed or load by providing either a voltage signal (0 to 5V DC or 0 to 10V DC), or a current signal (0 to 20mA or 4 to 20mA). Select the appropriate output from the CCS touch screen.

To save the changes and exit Analog Output press the ANALOG OUTPUT button or the Exit button.

◆◆ ANALOG OUTPUT 1

**Available Choices:** SIGNAL TYPE  
 MINIMUM  
 MAXIMUM  
 SOURCE

This output, OUT 1 (terminal 30, 31) is located on the Control board of the VSC 2000, and defaults to 0 to 5V proportional to Speed. Select alternatives according to the directions below.

To save the changes and exit Input 1 press the ANALOG OUTPUT 1 button or the Exit button.

**SIGNAL TYPE**

**Available Choices:** 0 - 5V  
 0 - 10V  
 0 - 20mA  
 4 - 20mA

Select the required output Signal Type from the available choices. A message will be displayed showing how the DIP switches block SW2 (SW4 for Output 2) must be set on the control board. Make note of the switch positions so that they can be set **after the power has been removed and the capacitors are fully discharged!!**. See the table below for switch positions:

Type	SW2-1 (Output 1)	SW2-2 (Output 1)	SW2-3 (Output 1)	SW2-4 (Output 1)
	SW4-1 (Output 2)	SW4-2 (Output 2)	SW4-3 (Output 2)	SW4-4 (Output 2)
0-5V	Closed (ON)	Open (OFF)	Closed (ON)	Closed (ON)
0-10V	Closed (ON)	Open (OFF)	Closed (ON)	Open (OFF)
0-20mA	Open (OFF)	Closed (ON)	Open (OFF)	Open (OFF)
4-20mA	Open (OFF)	Closed (ON)	Open (OFF)	Open (OFF)

To save the changes and exit Signal Type press the SIGNAL TYPE button or the Exit button.

**MINIMUM**

**Available Choices:** Enter Value..... (range: Signal Type dependent)

Both of the outputs have individual minimum and maximum adjustments. The Minimum is the value present on the analog output when the inverter is running at minimum speed. To set the Minimum value for the analog output enter the value, volts or milliamps, depending on the Signal Type.

To exit Minimum press the SIGNAL TYPE button or the Exit button.

**MAXIMUM**

**Available Choices:** Enter Value..... (range: Minimum + 10% of full scale to full scale - Signal Type dependent)

The Maximum is the value present on the analog output when the inverter is running at maximum speed. To set the Maximum value for the analog output enter the required value in volts or milliamps depending on the Signal Type selected. The minimum range on the analog output is 10% of the selected range (i.e. 0.5 V for a 0 - 5 V range). These minimum and maximum values are independent of the drives minimum and maximum frequencies.

To exit Maximum press the MAXIMUM button or the Exit button.

**SOURCE**

**Available Choices:** SPEED  
 LOAD  
 BIPOLAR LOAD  
 PID VARIABLES (see PID Controller section of manual)

Select which parameter is used for the Analog Output from the available choices. When **Speed** is selected, the output represents the speed of the VSC 2000. (Note direction can be indicated by a Digital Output.) When **Load** is selected, the output represents motor load. The Load Signal is scaled by the Nameplate Current setting; 100% Load Signal = 100% Nameplate Current, while 0% Load = approx. 10% Nameplate Current. The latter is due to minimum operating current needed to run the motor at no-load.

When **Bipolar Load** is selected the VSC 2000 can indicate whether the load is being driven or is regenerating, e.g. for a 0 to 5V output Signal Type (VSC 2000 with 110% overload capability) 5V indicates that the motor is driving the load at 110% of its capacity, 0V indicates that the motor is being driven by the load at 110% of its capacity (current is being re-generated), and 2.5V indicates a no load condition. Refer to the table below for sample indications:

Signal Type	Maximum Load Output (110% O/L)	Indication at 100 % (Rated) Load
0 to 10Vdc	10Vdc	9.1Vdc
0 to 5Vdc	5Vdc	4.5Vdc
0 to 20mA	20mA	18.2mA
4 to 20mA	20mA	18.5mA

◆◆ ANALOG OUTPUT 2

(see ANALOG OUTPUT 1 - NOTE: use SW4 on the control board to select Signal Type)

▶ **DIGITAL OUTPUTS**

**Available Choices:** RELAY 1  
RELAY 2  
OUTPUT J, K, L & M

Relays 1 and 2, and four optional control outputs J, K, L & M of the VSC 2000, can be individually programmed to indicate one of a number of status conditions or flags described below.

The four optional outputs J, K, L & M are available only when the Extended Features board is installed. Note that in Enhanced Terminal Configuration J,K,L & M are available as pre-assigned inputs only.

To connect (assign) an output or a relay to any of these flags/conditions, first select the Digital Output and then select the flag from the available choices described below. **Digital Outputs assignable flags.**

FLAG NAME	'TRUE' CONDITION
ZERO SPEED	Drive is at Zero Speed
RUN SIGNAL	Drive Enabled, Run and a direction (Fwd or Rev) selected
UNDER SPEED	The motor is running at a speed below the set-point specified
OVER SPEED	The motor is running at a speed above the set-point specified
AT SPEED	The motor is running at a speed equal to the speed reference
DRIVE ENABLED	Drive is Enabled (terminals 40 - 48 joined) (Terminal 48 is +24V)
FORWARD DIRECTION	Forward Signal latched
REVERSE DIRECTION	Reverse Signal latched
ON	Turns the selected Relay or Output ON
OFF**	Turns the selected Relay or Output OFF
PROOF**	Drive Enabled, not tripped (see 'HVAC Terminal Configuration')
ESO**	Drive running in ESO mode (see 'HVAC Terminal Configuration')
TRIP	A Trip condition has occurred and has not been cleared
MANUAL	Drive operation controlled through the CCS
PID I SATURATION <sup>+</sup>	PID integrator is saturating
PID OUTPUT SATURATION <sup>+</sup>	PID output is saturating
PV OVER ALARM <sup>+</sup>	Process variable is above the setpoint specified
PV UNDER ALARM <sup>+</sup>	Process variable is below the setpoint specified
AUTO RES. AVAILABLE	No. of auto restarts remaining, that is not yet used up
FAN LOAD WARNING	Fan load has changed indicating changes such as broken belts etc,
THERMAL TRIP	Trip by external thermal device sensors (microtherm or thermistor)
I <sup>2</sup> t TRIP	Trip due to overcurrent accumulation in I <sup>2</sup> t sensing
OVER TEMP TRIP	Over-temperature in drive enclosure or heat sink

\*\*All Relays energized / Outputs high for above true conditions, with the exception of those marked \*\*. <sup>+</sup> See the PID Controller section for further details.

To save the changes and exit Digital Output press the DIGITAL OUTPUT button or the Exit button.

▶ ▶ RELAY 1

**Available Choices:**

ZERO SPEED RUN SIGNAL UNDER SPEED OVER SPEED ▼	ON OFF PROOF ESO ▼	PV OVER ALARM PV UNDER ALARM AUTO RES. AVAILABLE FAN LOAD WARNING ▼
AT SPEED DRIVE ENABLED FORWARD DIRECTION REVERSE DIRECTION ▼	TRIP MANUAL PID I SATURATION PID OUTPUT SATURATION ▼	THERMAL TRIP I <sup>2</sup> t TRIP OVER TEMP TRIP ▼

Select from the available choices (see previous Flag Name descriptions in the table) and assign to the Relay 1 output.

To save the changes and exit Relay 1 press the RELAY 1 button or the Exit button.

▶ ▶ RELAY 2

(same as for RELAY 1 above)

▶ ▶ OUTPUTS J, K, L & M

These are available with Industrial, HVAC and Enhanced Terminals when an Extended Features board is installed and can be assigned a Flag Name as for RELAY 1 above. These outputs are not available in Enhanced Terminals with Motorised Pot since J,K,L & M are pre-defined inputs only.

Note load current limitations on DIGITAL OUTPUT of the Extended Features board as specified in the VSC 2000 Control Wiring Diagrams in the Installation Manual.

▶ **POWER ON CONFIG**

**Available Choices:** POWER ON MODE  
POWER ON SCREEN

▶ ▶ POWER ON MODE

**Available Choices:** AUTO, MANUAL

AUTO or MANUAL operation at power on. When power is applied to the VSC-2000 it can begin operation in either Auto mode (as per terminal strip wiring) or Manual mode (CCS control, default setting). A Power-Up Start-Up configuration would use AUTO Power On Mode for example, for a hands free start-up. To alter the setting select the preferred power on mode.

## ▶▶ POWER ON SCREEN

**Available Choices:** RUN  
METER READOUTS

Selecting RUN, the CCS will display the Run screen on power-up (default setting). Select METER READOUTS if you wish to display the Meter Readouts screen on power up of the VSC 2000.

Press the 'Exit' button when finished.

## ▶ CCS IN AUTO

**Available Choices:** CCS SPEED POT  
CCS STOP BUTTON  
CCS MAN BUTTON

This feature allows the CCS local buttons STOP and MAN-ual, and the SPEED pot. to be used in Auto. The default in Auto is STOP and MAN-ual enabled, and Analog Input IN 1 as the Speed reference signal. STOP is default enabled in Auto for safety considerations, where the other features can be enabled or disabled as needed, for example when testing systems where a drive is otherwise controlled by an external speed signal source. Note: SPEED pot. must be disabled in CCS IN AUTO if the MOTORIZED POT option is to function.

To save the changes and exit CCS in Auto press the CCS IN AUTO button or the Exit button.

## ▶ DISPLAY UNITS

**Available Choices:** Enter Value

The VSC 2000 is able to display motor speed in user defined units. The default setting is motor output frequency (in Hz) but it can very easily be changed at any time, so that the display will show for example, **mtr/min**, Cans/hr or anything else (up to 8 characters). To change the Display Units first delete the existing setting using the Delete (◀) Button and then enter the desired units. Pressing the Next Page (▼) Button will give you access to lower case as well as some more special characters.

To save the changes and exit Display Units press the DISPLAY UNITS button.

## ▶ DISPLAY SCALE

**Available Choices:** Enter Value

Similarly to the user defined Speed Units, the Display Scale is also easily customized. The default setting is the motor output frequency value in Hz (50 or 60Hz depending on the Maximum Frequency setting) but it can be changed to any

number from 0 to 9999 (or 999.9 with one decimal place) - if zero is entered the inverter will still run normally but the Run Screen will always show '0' for speed.

Note that for all Speed settings (Preset Speeds, Skip Speed, Jog Preset, Override Preset, Under/Over and At Speed) will depend on the Display Scale and will change when a new Display Scale is entered.

To save the changes and exit Display Scale press the DISPLAY SCALE button or the Exit button.

## ▶ SLIP COMP

**Available Choices:** Enter Value(range: 0 to 150%)

To use Slip Comp the Automatic Boost setting must be set for best performance at low speed (see ▶ AUTOMATIC BOOST). The VSC 2000 is capable of compensating for the slip of the motor to maintain constant shaft speed under varying loads. It does this by changing the output frequency by the correct amount to maintain motor shaft speed.

The motor slip is calculated from the Nameplate Speed of your motor that is entered at the MOTOR parameters menu (see ▶ MOTOR). The value for Slip Comp is entered as a percentage of this slip speed. A value of 100% will fully compensate for the motor's slip.

In Slip Comp the motor load signal is used to determine the actual slip of the motor therefore the accuracy of this control is determined by the accuracy of the load signal, which is excellent at high speeds but not as exact in the low speed range, typically below 10 Hz, due to increased losses (as discussed under Automatic Boost) in the motor which are included in the load signal. This however is dependent on the motor efficiency, the more efficient the motor the greater the accuracy at low speed. Usually, however accuracy better than 1% is achievable.

A 50 Hz motor with a synchronous speed of 1500 and a nameplate speed of 1460 rpm has a 40 rpm difference that is the slip at synchronous speed. Slip Comp set at 100% will cause the VSC 2000 to raise output frequency to the motor such that it runs at 1500 rpm. A Slip Comp setting of 50% would see the motor run at 1480 rpm.

To save the changes and exit Slip Comp press the SLIP COMP button or the Exit button.

## ▶ START DELAY

**Available Choices:** Enter Value.....(range: 0.1 to 109.2 minutes)

This features imposes a timed delay before the motor is started. The delay commences immediately after a valid start condition (power on start, CCS FWD/REV, control terminals 40, 42 and 43 or 44 connected to +24V, etc)

▶ **AUTO RESTART**

**Available Choices:** NUMBER OF RESTARTS  
 RESET TIME  
 ENABLE  
 DISABLE

Auto Restart allows the VSC 2000 to automatically restart after a trip occurs. After a trip the VSC 2000 will wait 10 seconds then attempt to reset the trip. If unsuccessful it will keep trying, incrementing the trip count each time, until the Number of Restarts is reached. If the trip count reaches the Number of Restarts the VSC 2000 will cease attempts to restart until manually reset via the local or remote controls. A successful restart will clear the trip count to 0, but only after the drive has run for the Reset Time.

To exit Auto Restart press the AUTO RESTART button or the Exit button.

▶▶ **NUMBER OF RESTARTS**

**Available Choices:** 5, 10, 15  
 Custom..... (range: 2 to 15)

This number indicates how many times the VSC 2000 will attempt to restart after a trip.

To exit Number of Restarts press the NUMBER OF RESTARTS button or the Exit button.

▶▶ **RESET TIME**

**Available Choices:** 1, 5, 10 min  
 Custom..... (range: 0.1 to 20 min)

The trip count will be reset to 0 after the inverter has been running for the programmed Reset Time without any further trips occurring, or if the inverter is manually stopped and reset using local or remote controls. Note: Setting the Reset Time to 0.1 will allow unlimited restarts.

To exit Reset Time press the RESET TIME button or the Exit button.

▶▶ **ENABLE / DISABLE**

Select ENABLE (DISABLE) in order to activate (de-activate) Auto Restart.

To exit Auto Restart press the AUTO RESTART button or the Exit button.

▶ **POWER FAIL TRIP RESET**

**Available Choices:** ENABLE  
 DISABLE

Enabling this facility allows the VSC 2000 to reset all trips when a momentary power failure occurs. This happens without an operator having to press the Stop button or the remote Trip Reset button.

To save the changes and exit Power Fail Trip Reset press the POWER FAIL TRIP RESET button or the Exit button.

▶ **PRESET SPEEDS**

**Available Choices:** PRESET 1  
 PRESET 2, PRESET 3,...4, 5, 6.

The VSC 2000 allows the user to program up to six preset speeds which can be selected at any time through the terminal strip using Control Inputs F, G and H. For Industrial and HVAC terminal configurations, only Presets 1 and 2 are available. The desired Preset Speed is activated by forcing the appropriate control terminal inputs to a high state. With an Extended Features board installed Presets 1 to 6. For more information on how to select the Preset Speeds see the Terminal Configuration pages in the **VSC 2000 Installation Manual**.

To exit Preset Speeds menu press the PRESET SPEEDS button or Exit button.

▶▶ **PRESET 1**

**Available Choices:** Custom(range: 0 to 200Hz limited by the Maximum Speed setting)

Enter the desired value by using Custom. A value less than the Minimum Frequency setting will not be accepted by the VSC 2000 and the preset value will be made equal to Minimum Frequency setting.

To save the changes and exit Preset 1 press the PRESET 1 button.

▶▶ **PRESET 2, 3, 4, 5 & 6**

(See PRESET 1 above)

▶ **SKIP SPEEDS**

**Available Choices:** SKIP 1  
 SKIP 2, ...3, 4.

The VSC 2000 may be set up to skip (jump over) four independent user programmable frequencies. This facility is of utmost importance in systems where the mechanical resonant frequencies lie within the range covered by the inverter. Skipping these frequencies will cause the motor to be driven through them without stopping which will avoid any mechanical damage.

If for example, a Skip Speed is 25Hz and the range is 5Hz, then frequencies from 20 to 30Hz are skipped. If the speed reference is set between 20 and 25Hz, the drive will run at 20Hz. If the speed is set between 25 and 30Hz then the drive will run at 30Hz. A Skip setting must be enabled to operate.

To program the frequencies to be skipped select one of the Skip Speeds by pressing the appropriate button first and follow the directions below to enter the desired value.

Note that changing the Display Scale from default (50 or 60Hz) to any other scale also changes the Skip Speed units automatically. Ensure Skip Speeds are always entered according to Display Scale units.

To exit Skip Speeds press the SKIP SPEEDS button or Exit button.

### ▶▶ SKIP 1

**Available Choices:** SPEED  
RANGE  
ENABLE  
DISABLE

This is one of the four Skip Speed settings available.

To exit Skip 1 press the SKIP 1 button or Exit button.

#### **SPEED**

**Available Choices:** Enter Value.....(range: 0Hz to Maximum Frequency setting)

Enter the speed to be skipped using the keypad. The speed entered is in user units.

#### **RANGE**

**Available Choices:** Enter Value.....(range: 0Hz to Maximum Frequency setting)

This sets the band to be skipped before and after the desired Skip Speed. Enter the Range using the keypad. The range is entered in user units.

#### **ENABLE**

Enables Skip Speed 1

#### **DISABLE**

Disables Skip Speed 1

### ▶▶ SKIP 2, 3 & 4

(See SKIP 1 above).

## ▶ JOG

### ▶▶ SPEED SOURCE

**Available Choices:** JOG PRESET

Enter Value..... (range: 0Hz to Maximum Frequency setting)

INPUT 2

Selecting a speed source will select the speed at which the VSC 2000 will run when the Jog contact (Control terminal 45 for HVAC and Industrial, or Control Terminal 82 for Enhanced terminals) is closed. There are two references that can set the Speed; JOG PRESET or INPUT 2.

#### **JOG PRESET,**

Selecting JOG PRESET means the drive will run at the constant speed set. Enter the desired speed as if it was a custom setting.

**Note: the Jog feature** is disabled when the VSC 2000 is operating in Essential Services mode.

#### **INPUT 2**

Choose INPUT 2 to operate Jog speed override from a variable external speed reference. The reference source is connected to Control Input IN 2 (terminals 14 and 15). If the value entered is lower than the Minimum Frequency setting the VSC 2000 will run at the Minimum Frequency. If the value entered is higher than the Maximum Frequency setting then it is automatically changed to the Maximum Frequency.

## ▶ ESSENTIAL SERVICES

**Available Choices:** ENABLE  
DISABLE  
TIME ENABLED  
TIME STRESSED

Essential Services Override (ESO) provides the ability to override all VSC 2000 control inputs via a contact closure to a single VSC 2000 control input. Essential Services is only available when HVAC Terminals are selected.

For HVAC applications it is often a requirement for the VSC 2000 to operate under special conditions to provide Essential Services e.g. for running emergency ventilators in Fire Stair wells or Underground Car parks.

Enabling this feature means that when the ESO contact is closed, all control inputs to the drive will be overridden and the drive will run forward at the override speed. ESO is engaged from the terminal strip via Control Input F being set high (Control input terminal 45 to terminal 48 i.e. +24 V) - see **VSC 2000 Installation Manual**.

Once ESO is engaged the VSC 2000 cannot be stopped by any other Control Input or via the CCS control panel. Only releasing the Speed Override input at the terminal strip will take the VSC 2000 back to normal operating mode.

In ESO the drive control will also ignore over-temperature trips and will attempt to restart after any other trip occurs, indefinitely. This is intended so that the drive controls the motor for the longest time possible under emergency conditions, even if the eventual result is the failure of the VSC 2000, for example, due to over-temperature.

▶▶ **ENABLE, ▶▶ DISABLE**

**Available Choice:** SPEED SOURCE

To select ESO, the terminal configuration must be HVAC TERMINALS and a Speed Source and Speed should be set as required. When Essential Services is selected in the CCS menu, and Enable is pressed, an important Warning message appears. Press 'OK' after you have read the message. Overwrite the 'xxxx' in the next screen using the factory preset access code (PIN) which is 1470 and press the PIN button. This is done to ensure that this feature cannot be enabled by accident. Now select a Speed Source for the ESO operation. (NOTE: once ESO has been enabled, restoring the HVAC defaults will not disable it and selecting Industrial Terminals will not be allowed).

**WARNING:** With ESO engaged (Essential Services enabled and control input F high) the ENABLE, RUN/STOP and the Comprehensive Control Station STOP (in AUTO or MAN) **ARE DISABLED!** The VSC 2000 can only be stopped by opening control input F and applying a Stop signal. All thermal trips are ignored and all other trips are AUTO RESTART-ed indefinitely. **Note:** Warranty can be void if the drive is stressed (ie. If any trips are ignored) during ESO.

**SPEED SOURCE**

**Available Choices:** OVERRIDE PRESET- Enter Value .....  
(range: 0Hz to Max. Frequency setting)

INPUT 2

This allows the selection of the speed source used for Speed Override. Selecting OVERRIDE PRESET means the drive will run at the constant speed you set. To operate ESO from a variable external speed reference, choose INPUT 2. The reference source is connected to Control Input IN 2 (terminals 14 and 15). If the value entered is lower than the Minimum Frequency setting the VSC 2000 will run at the Minimum Frequency. If the value entered is higher than the Maximum Frequency setting then it is automatically changed to the Maximum Frequency.

▶▶ **TIME ENABLED**

Pressing Time Enabled displays the time at which the ESO function was enabled.

▶▶ **TIME STRESSED**

Pressing Time Stressed displays the time at which the VSC 2000 has run in ESO and at least one of the trip signals was present and was ignored.

To save the changes and exit Essential Services press the ESSENTIAL SERVICES button or the Exit button.

▶ **AUDIBLE FREQUENCY**

**Available Choices:** AUTOMATIC SELECTION  
2.0, 4.0, 6.0, 8.0 kHz  
10.0, 12.0, 14.0, 16.0kHz

The Audible (or carrier) Frequency is the frequency at which the output transistors switch to produce the PWM. This switching produces the audible noise on the motor. Generally the higher frequencies produce less noise but also increase the switching losses which results in additional heating within the drive. **For most efficient operation select 2 kHz.** If problems with EMC type interference are encountered also select 2 kHz which may reduce these problems in some cases.

In the Automatic (default) setting, the VSC 2000 monitors internal heating and if necessary will reduce the Audible Frequency to ensure continuous operation. If the ambient temperature or the load increases, the VSC 2000 will then step the frequency down in 2kHz steps, to reduce heat dissipation, limiting losses. In Automatic the VSC 2000 will operate at the highest Audible Frequency possible. It also operates to deliver more power to the motor at or near full speed by reducing Audible Frequency.

When frequency is reduced near 50 Hz, the motor noise spectrum is more spread out in a similar effect to random modulation. The result is that audible effects of a lower carrier frequency are less noticable at high speed. If the application requires quiet operation, then selecting a suitable Audible Frequency will dissable this feature.

To save the changes and exit Audible Frequency press the AUDIBLE FREQUENCY button or the Exit button.

▶ **DRIVE STOPPING**

**Available Choices:** RAMP TO STOP  
COAST TO STOP  
DC BRAKE

This controls the operation of the VSC 2000 when a stop signal is given. It applies when either the stop button is pressed on the CCS or the RUN terminal is opened on the terminal strip.

◆◆ RAMP

Ramp to Stop means that when the Stop button is pressed the VSC 2000 will continue to control the motor in order to bring it to a stop in the time set by the Decel time.

◆◆ COAST

Coast to Stop means that when the Stop button is pressed the VSC 2000 will stop controlling the motor (stop switching) and allow the motor to coast to a stop, just as if the power supply had been disconnected.

◆◆ DC BRAKE

DC Brake causes a braking torque to be applied to the motor. When the Stop button is pressed, the drive output switching stops and there is a 2 second delay to allow for field de-fluxing. Then a controlled DC current is applied across the motor windings to create a braking torque. See DC Braking for more information on this feature.

To save the changes and exit Drive Stopping press the DRIVE STOPPING button or the Exit button.

◆ DC BRAKING

Available Choices: DC BRAKE STRENGTH  
DC BRAKE DURATION

DC Brake Strength is entered as a percentage of maximum (ie. intermittent current rating = 110% x continuous rating) drive current from 1 to 100% and determines the level of DC current shared across the motor windings to affect DC braking. DC Brake Duration is set to a value in seconds from 1 to 60. During braking I<sup>2</sup>t protection will trip the drive if excessive current is applied to the motor.

◆ DYNAMIC BRAKING

Available Choices: ENABLE  
DISABLED

Dynamic Braking provides the means for dissipating the motor regenerative energy into an external resistor. Dynamic Braking (when fitted) operates anytime the VSC 2000 experiences regenerative currents from an overhauling load, that is, any motor with a high inertia or a motor that is required to decelerate rapidly. A VSC 2000 with Dynamic Braking option fitted, needs only the external braking resistor connected to it and the function enabled via the CCS. A Dynamic Braking Module Retro-fit Kit can be obtained to install dynamic braking into a VSC 2000, see the table below for part numbers.

Selecting the Braking Resistor

The resistance value and the power rating must be calculated from the motor or shaft power. For a 480V rated VSC 2000, ie a drive with the following model number VSC-2GXXX, the dc bus voltage to use in calculations is 750V. (This is calculated from 480 V x 1.1 x √2 = 750 V. The 1.1 is used as the +10% tolerance figure of the supply voltage.) Firstly, determine the current:

$$I_{res} = \frac{P_{motor} \times \eta}{750}$$

η = motor efficiency = 0.95 to 0.97 for most large motors and 0.90 to 0.95 for smaller.

Now calculate the value of resistance to achieve I<sub>res</sub>;

$$R_{max} = \frac{750}{I_{res}}$$

A minimum resistance value must also be calculated so as to not exceed the braking transistor (IGBT) current rating. Use the table below to determine R<sub>min</sub> for the 480V case. , R<sub>min</sub> was calculated using the same formula as for R<sub>max</sub> , replacing I<sub>res</sub> with I<sub>IGBT</sub>.

VSC 2000 Model (480V)	Braking IGBT Amp	R <sub>min</sub>	Braking Module Retro-fit Kit
2G14	50	15	ID00083
2G27	50	15	ID00083
2G41	50	15	ID00083
2G55	75	10	ID00084
2G82	75	10	ID00084
2G109	100	7.5	ID00085
2G143	150	5	ID00086
2G190	150	5	ID00086
2G203	200	3.75	ID00087
2G271	200	3.75	ID00087

The Braking transistor IGBT can operate continuously (i.e. Duty cycle, D = 1) provided R<sub>min</sub> or greater is used. Now the power rating of the resistor can be calculated from the motor duty cycle. The duty cycle should be determined as:

$$D = \frac{\text{time\_in\_braking}}{\text{cycle\_time}}$$

It is a number between 0 and 1. If D is less than 0.2 (or 20%) then make it 0.2. This is to ensure that the minimum power rating of the resistor is adequate to handle a full braking load, without catastrophic failure. The duration of the braking period determines the temperature rise of the resistor as determined by the thermal time constant of the resistor. If the 'braking' is prolonged, as might be the case with an over-hauling load such as a conveyor belt heavily loaded, going downhill, then the dynamic brake will be working continuously and the resistor will heat up accordingly.

In typical applications braking is intermittent ( $D \ll 1$ ), therefore the resistor rating does not need to be for continuous operation but rather could be sized according to an average value of the power dissipation over the cycle time. Even though the instantaneous intermittent power may exceed this rating, if the resistor time constant is longer than the braking period, the resulting resistor temperature rise over the cycle time may still be acceptable and the resistor will handle the load.

$$P_{res} = \frac{750^2 \times D}{R}$$

### Installing the Braking Resistor

Wire the resistor to the two terminals labeled BR+ and BR- in the VSC 2000. Also fit a thermistor in the resistor so that the resistor is protected from excessive loading / over-heating. The thermistor should open an isolation contactor fitted in series with the supply input to the VSC 2000. Locate the braking resistor away from the drive in an area with sufficient cooling for the resistor. Cooling fans may be useful.

### Enabling Dynamic Braking

Before running the drive, ensure that it is programmed correctly. Firstly, select the appropriate drive stopping mode. Press SETUP, then COMPLETE SETUP and then scroll down (▼) until DRIVE STOPPING appears. RAMP TO STOP or COAST TO STOP may be selected, but DC BRAKE should not be used. Exit and then press DYNAMIC BRAKING. Ensure that it is enabled - press Enable if necessary. Now the drive is able to use the braking resistor to decelerate rapidly or to come to a quick stop. Be sure that RAMPs are programmed correctly.

## ▶ MOTORIZED POT

Available choices: DISABLE  
PERSISTENT MODE  
RESET MODE  
PRE-LOAD

This feature enables the drive speed to be adjusted via remote push-buttons, one for speed increase, another for speed decrease. Motorized Potentiometer operates via terminals J and K on the Extended Features (EF) board in Enhanced Terminal Configuration. All Terminals J,K,L & M are inputs only in Motorised pot.

Terminals on the Control board are set up as shown in the **Control Wiring Diagrams** in the **VSC 2000 Installation Manual**, page 12. Note that Speed Reference must be selected in Control Wiring for Motorised Pot via Speed Reference Control Input Terminals F, G and H set (*low, low & high*) as per Enhanced Terminal Configuration tables in Installation Manual, page 9. Closing

terminal input J (J = *high*) increases the output frequency of the drive and closing input K (K = *high*) decreases it. Closing the two inputs will force the speed to zero.

**Note:** To use Motorised Pot., the local CCS SPEED pot must be disabled via CCS IN AUTO.

To save the changes and exit Remote Motorized Potentiometer press the MOTORISED POT or the Exit button.

### ▶▶ DISABLE

Selecting this option disables the Remote Motorized Potentiometer and allows Analog Input 2 to be used as a normal analog speed reference input.

### ▶▶ PERSISTENT MODE

This is the default mode of operation of Motorized Pot. In this mode Motorized Pot remembers its previous speed setting and will return to that speed when it is selected or the drive is stopped and restarted.

### ▶▶ RESET MODE

In this mode the Motorized Pot will always start from zero if the motor or the drive is stopped and restarted.

### ▶▶ PRELOAD

This sets the Motorized Pot to save the current speed setting regardless of the speed reference used. Next time Motorized Pot is selected the drive will return to that speed. The drive will still operate in accordance with the Motorised Pot mode that has been selected (Persistent or Reset).

## ▶ PID CONTROLLER

Described in the PID CONTROLLER section at the end of this manual.

### ▶ TACHO FEEDBACK

Tacho Feedback configures and initiates the VSC 2000 for a speed control system by utilizing the drive's PID feature. A default set of parameters are loaded and PID control is enabled to offer a conservative (over-damped) closed-loop performance. If the default settings for Tacho Feedback are not satisfactory they may be adjusted via the PID Controller menu. Default Tacho Feedback PID Settings are given in the table below:

Setting	Default Value
PB (%)	300
Ti (sec/r)	2
Td (sec)	0
INTEGRATOR PRESET	0
I+ CLAMP %	100
I- CLAMP %	100
OUTPUT+ CLAMP %	100
OUTPUT- CLAMP %	0
SET POINT VARIABLE	INPUT 1
FEED FWD	ZERO
EXTERNAL OPEN/CLOSE	DISABLED

Tacho Feedback is Disabled via the PID Controller menu when PID Controller is Disabled. For further details on the PID Controller refer to the PID CONTROLLER SUPPLEMENT at the end of the manual.

### DISPLAY

**Available Choices:** DARKER  
LIGHTER  
SERIAL NUMBER

This menu allows the user to change the contrast of the digital display and to display the Serial number of the CCS.

#### ▶ DARKER

This option darkens the LCD little by little each time the button is pressed.

#### ▶ LIGHTER

This option lightens the LCD little by little each time the button is pressed.

#### ▶ SERIAL NUMBER

Displays the Serial Number of the Comprehensive Control Station. The Serial Number cannot be erased or altered.

IM02000F

To exit the Display menu press the Exit button.

### LANGUAGE

**Available Choices:** ENGLISH, SWEDISH  
SPANISH, MALAY

The VSC 2000 Comprehensive Control Station (CCS) has the ability to display different languages. Once selected, all messages appearing on the display will be in the selected language.

Note: The language selection is permanently stored in the Data Card which means that the VSC 2000 will remain in the selected language even after the power is switched off and on again. If the incorrect language is displayed, it can be reprogrammed: Turn the drive off and wait for the CCS screen to go blank; Turn the drive on; Press the button in the top left corner of the screen; Press the third button down on the right; Select the language you understand.

### METER READOUTS

This screen provides information about the drives current operating conditions. The parameters displayed are:

- Output Speed (Hz)
- Output Current (A)
- RPM (RPM)
- DC Bus Voltage (Vdc)
- Motor Load in % (%L)
- Motor power in kW. (KW)

Meter readouts are also available individually from the RUN screen by pressing over the top right corner of the screen. To cycle through each parameter keep pressing this corner of the screen.

### SERVICE

**Available Choices:** FAN CONTROL  
PHASE FAILURE TRIP  
POWER FAILURE TRIP  
IMBALANCE TRIP

This set of features allows the user to obtain more information and control some of the internal parameters of the VSC 2000.

**WARNING: DISABLING ANY TRIP FEATURE MUST BE DONE WITH CARE!**

▶ **FAN CONTROL**

**Available Choices:** INTERNAL FAN  
HEATSINK FAN

This allows independent control of the built-in fans of the VSC 2000: the Internal Fan and the Heatsink fan. Each of these fans can be set-up to run continuously or in Automatic mode, which means that the fans only run after a specific internal temperature is reached (35°C for the Internal Fan and 45°C for the Heatsink Fan).

▶▶ **INTERNAL FAN**

**Available Choices:** ON  
AUTO

Internal Fan operates continuously or in Automatic mode.  
To exit Internal Fan press the INTERNAL FAN button or the Exit button.

▶▶ **HEATSINK FAN**

**Available Choices:** ON  
AUTO

Internal Fan operates continuously or in Automatic mode.  
To exit Heatsink Fan press the HEATSINK FAN button or the Exit button.  
To exit Fan Control press the FAN CONTROL button or the Exit button.

▶ **PHASE FAILURE TRIP**

**Available Choices:** ENABLE  
DISABLE

This feature may be used for DC supply applications to avoid the Phase Failure sensing causing a trip.

**WARNING !:** Disabling the phase failure trip may subject the input power circuits to potentially damaging currents under certain conditions.

▶ **POWER FAILURE TRIP**

**Available Choices:** ENABLE  
DISABLE

This feature can be used for power failure ride-over or to allow for transfer to UPS supply in the event of mains failure.

**WARNING !:** Disabling power failure may subject the input power circuits to potentially damaging currents under certain conditions.

▶ **IMBALANCE TRIP**

**Available Choices:** ENABLE  
DISABLE

This feature can be used for overriding false drive output phase imbalance trips due to excessive and repeated load fluctuations.

**THERMAL DISPLAY**

This screen displays the current temperature readings of all of the internal temperature sensors installed on the drive. The number of sensors fitted depends on the size of the drive. An indication of "NF" will be shown next to the sensor number if that particular sensor is not fitted.

Sensor 0:, is internal ambient air temperature. 1:, 2:, 3: etc. are all heatsink temperatures, the number of sensors depending on the chassis size. These are used for service purposes.

To exit Temp 1 press the Exit button.

**RUN LOG**

The VSC 2000 logs the elapsed running time of the motor. The log accumulates time for 65,536 hours or about 7.5 years.

**TRIP LOG**

**Available Choices:** DISPLAY  
PF UV MASK  
CLEAR

The TRIP LOG feature logs the last 10 trips with the latest trip represented by the number 1 and the oldest trip represented by number 10. In the event of a trip the VSC 2000 records the internal status and the value of the Run Log or the date and time if an Extended Features card is installed.

▶ **DISPLAY**

This displays information in the trip log. The format is shown by the example below.

<b>Exit</b>	▽
<b>1:</b>	<b>25/02/97</b>
	<b>12:56:21</b>
	<b>802000000</b>
	<b>9C0000002</b>
<b>Over Current</b>	

Description of the screen; The '1' represents: the trip event number, '25/02/97': the date of the trip, '12:56:21': the time of the trip, '802000 000 9C0000002': an internal code which is used for communication via the RS-485 serial output, 'Over Current': the trip event description message.

▶ PF / UV MASK

**Available Choices:** ENABLE  
DISABLE

Power Failure (PF) / Under Voltage (UV) mask. This is a mask that can be set so that the Trip Log will ignore tripevents caused by Power Failure and Under Voltage, that will occur during power down of the drive.

▶ CLEAR

Clear the current fault log accumulated data.

▶ DATE

**Available Choices:** Enter Value ..... (range: up to 12/12/2055)  
Enter the current date in the format DD-MM-YY (day - month - year), e.g. enter 1 June 1996 as 01/06/96. When the Extended Features (EF) board is installed, the VSC 2000 will maintain the correct date even when power is removed. Without the EF Board installed the date defaults to 01/01/94 every time power is applied.  
To save the changes and exit Date press the DATE button.

▶ TIME

**Available Choices:** Enter Value.....(range: 00:00:00 to 23:59:59)  
Enter the current time in 24 hour format. When the Extended Features (EF) board is installed, the VSC 2000 will maintain the correct time even when power is removed. Without the EF Board installed the time defaults to 00:00:00 every time power is applied.  
To save the changes and exit Time press the TIME button.

RS-485 SETUP

**Available Choices:** DRIVE ID NUMBER  
BIT RATE  
DATA FORMAT  
2/4 WIRE

Refer to the dedicated RS-485 Communications Supplement at the end of this manual for details.  
IM02000F

▶ DRIVE ID NUMBER

**Available Choices:** Enter Value.....(range: 0 to 31)

Enter the drive ID number using the CCS touch screen. To exit press DRIVE ID NUMBER or exit.

▶ BIT RATE

**Available Choices:** 19200  
9600  
4800  
2400

Select the bit rate required from the available choices. This must be consistent with the setting of the communicating master (PC, etc).

▶ DATA FORMAT

**Available Choices:**n81 (no parity, 8 data bits, 1 stop bit)  
e71..... (even parity, 7 data bits, 1 stop bit)  
o71..... odd parity, 7 data bits, 1 stop bit)

Select the required data format from the available choices. This must be consistent with the setting of the communicating master (PC, etc).

▶ 2/4 WIRE

**Available Choices:** 2 WIRE  
4 WIRE

Select the required wiring topology. 2 WIRE operation means that communications is half duplex (a communicating device cannot send and receive at the same time). 4 WIRE operation means that communications is full duplex (a communicating device can send and receive at the same time).

FACTORY CONTROLS

**Available Choices:** ENABLE  
DISABLE

In the event that an alteration to a factory preset control is required in the field for a specific application, detailed instructions will be provided.

Press the FACTORY CONTROLS button or the Exit button to exit Factory controls.

--This is the end of the menu selections from the **Setup** screen

## PID CONTROLLER

### Contents

Section	Page
PID STRUCTURE.....	23
PID SPECIFICATIONS .....	24
PID CONTROL WIRING .....	26
PID SOFTWARE MENU STRUCTURE .....	27
SETUP-CHECKLIST AND TUNING.....	27
DEFINITION OF PID SETTINGS.....	29

### PID Structure

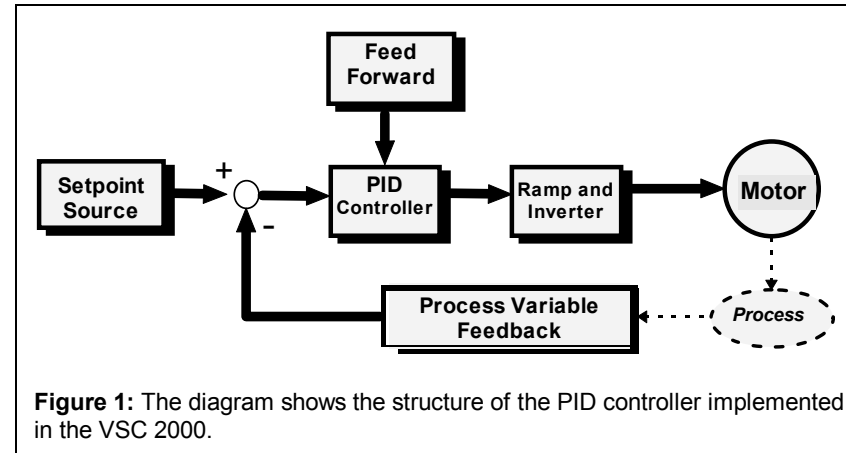

PID controllers (also referred to as Three-Term controllers), are used to stabilize and/or regulate a process at a desired operating point. PID controllers do this by sampling a measured process quantity (Process Variable Feedback) and then calculate an error signal using the required process set point (Setpoint Source). The error signal is then used to drive the process until the operating point is equivalent to the set point.

Using the VSC 2000 frame work the PID controller implements a Three-Term controller whose features include:

- Adjustable Integrator anti-windup
- Adjustable Integrator preset
- Adjustable Output saturation
- Selectable Setpoint and Feed Forward Input signals
- Accessible PID controller signals
- Input/Output signal spanning
- Process variable UNDER and OVER Alarm.

For a complete description of PID variables and settings see **Definition of PID Settings**.

## PID Specifications

### Display

- CCS LCD back-lit display.
- Display variables: Set-point Variable, Process Variable, Bar Graph.
- Each Variable has up to 4 digits.
- Custom units and display scaling.
- Meter readout display.
- Clamp indication Messages.

### Analog Input

- Two Analog Inputs with range:  
0 - 5V, 0 - 10V, 0 - 20mA, or 4 - 20mA.
- One input is available for Process Variable Input signal, while the other is available for Set-Point or Feed-Forward signal.
- Adjustable span.
- Reverse acting settable.
- Single ended earth referenced or differential.

### Analog Output

- One 0 - 5V, 0 - 10V, 0 -20mA, or 4 -20mA output is available.
- Galvanically isolated to  $\pm 42$  Vdc.
- Note: Second output is available with an optional extended features card fitted.
- Available outputs include: PROCESS VARIABLE, PID I SIGNAL, PID OUTPUT.
- Adjustable span.

### Digital Output

- Two relay outputs as standard, and up to 4 Digital outputs with an optional Extended Features card fitted.
- Referenced to +24V and digital common.
- Outputs include: PID I SATURATION, PID OUTPUT SATURATION, PV OVER ALARM, PV UNDER ALARM.

### Proportional Band

- Adjustable range 0..999.9 %.

### Integral Time

- Adjustable range 0.05..19.99 seconds per repeat.

### Derivative Time

- Adjustable range 0.25..5.00 seconds.

### Integrator Clamp

- Adjustable range  $\pm 100$  % of maximum frequency setting.
- Clamp indication message on display.

### PID Output Inversion

- simple inversion by enabling a menu feature.

### Output Clamp

- Adjustable range  $\pm 100$  % of maximum frequency setting.
- Clamp indication message on display.

### Set Point Input

- Selectable from: Control terminals 45, 46 & 47

### Feed Forward Input

- Selectable from: Zero, IN 1, CCS Speed Pot, or Preset 1..6.

### Resolution

- $\pm 32,767$  steps.

### Accuracy

- 0.2% - 10 bit sampling, 1024 steps  $\pm 1$  step

### Sample Time

- 50 ms.

### Alarms

- PV Under/Over Alarms
- Alarm response time  $\leq 60$  ms.

### Open/Closed Loop Control

- Via AUTO/MAN CCS push buttons.
- Externally selectable via 24V digital input with an optional Extended Features card fitted.

PID CONTROL BLOCK DIAGRAM

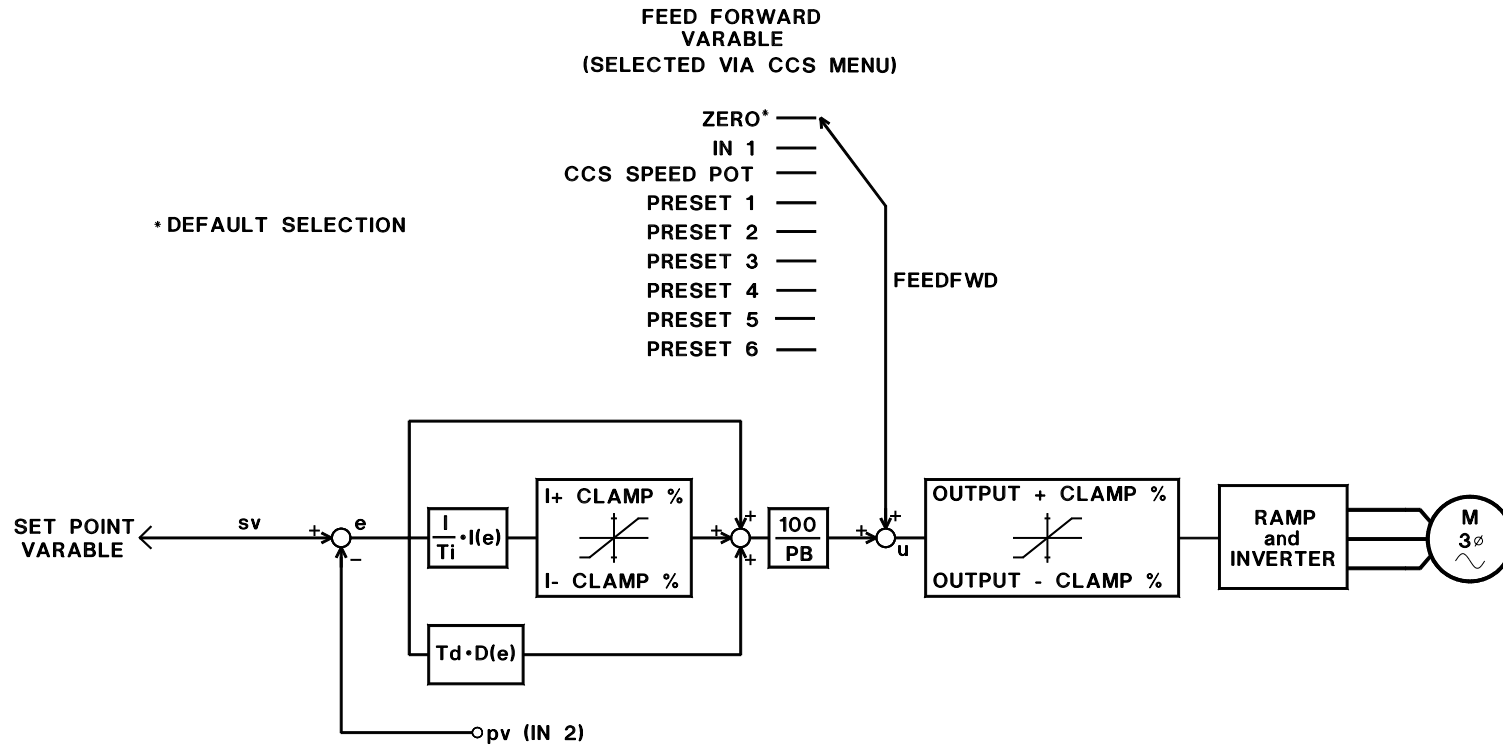

LEGEND:

- sv Setpoint reference signal
- pv Process feedback signal
- e Error signal (e = sv - pv)
- u Control (Motor Speed) Signal
- FEEDFWD Feed forward signal
- I+ CLAMP % Positive integrator limit
- I- CLAMP % Negative integrator Limit
- OUTPUT+ CLAMP % Positive Output limit
- OUTPUT- CLAMP % Negative Output limit
- I(e) Integral of the error signal e
- D(e) Derivative of the error signal e
- PB Proportional band percentage
- Ti Integral time
- Td Derivative time.

When operating linearly, this structure implements the following equation.

$$u = \frac{100}{PB} \times \left( e + \frac{1}{Ti} I(e) + Td * D(e) \right) + FEEDFWD$$

15295001

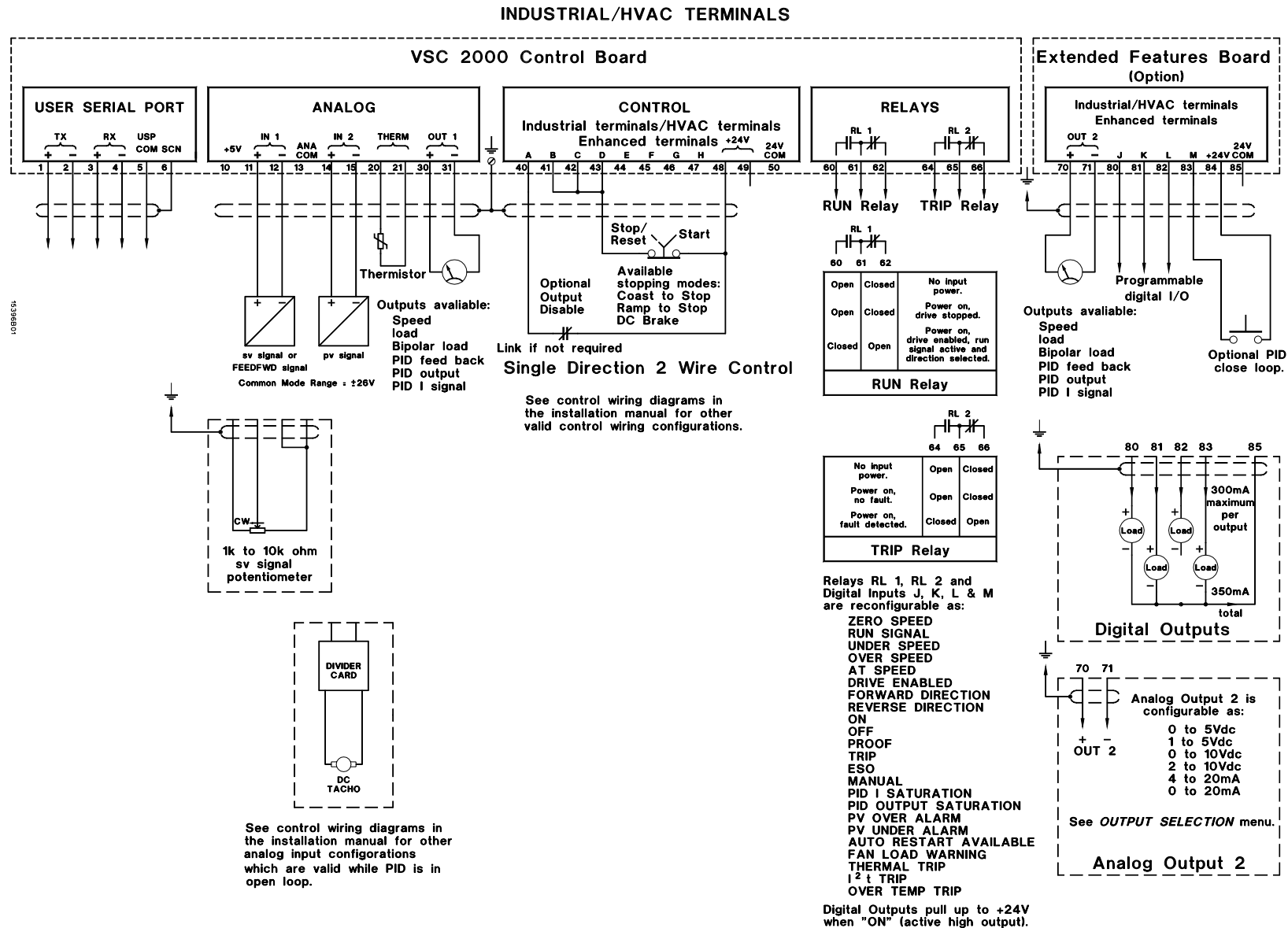

**PID Software Menu Structure**

PID parameters and settings are entered through Comprehensive Control Station (CCS) menus. The following sections describe each parameter and its role in PID control.

The PID menus appear in the COMPLETE SETUP menu. There are four PID menus, the first of which is to enable or disable the PID controller. The remaining three menus are accessed from the first menu by selecting PID PARAMETERS and are for selecting the PID parameters and or altering their settings. For definitions of PID settings see the **Definitions** section at the end of the manual.

▶ **PID Controller**

- Available Choices:** ENABLE  
 DISABLE  
 PID PARAMETERS

Enable or Disable PID functions. Pressing the PID PARAMETERS menu item provides access to the parameter entry menus described below. To exit PID CONTROLLER press 'Exit'.

Press the ▲▼ up/down arrow symbols to go to the next PID Parameters menu.

▶▶ **PID PARAMETERS**

- Available Choices:** (Defaults)
- PB (%) ..... 300%
  - Ti (sec/r) ..... 2.00 sec/r
  - Td (sec) ..... 0 sec
  - INTEGRATOR PRESET ..... 0%

- Available Choices:** I+ CLAMP % ..... 100%
- I- CLAMP % ..... -100%
  - OUTPUT+ CLAMP % ..... 100%
  - OUTPUT- CLAMP % ..... 0%
- (Note: a negative value indicates the reverse direction).

- Available Choices:** FEED FWD ..... ZERO
- EXTERNAL OPEN/CLOSE ..... Disabled
  - OUTPUT INVERSION ..... Disabled

Alternative sources available for the FEED FWD assignments are:

ZERO	PRESET 1	PRESET 4
INPUT 1	PRESET 2	PRESET 5
CCS SPEED POT	PRESET 3	PRESET 6

**Setup-Checklist (✓) and Tuning**

1. Control Wiring
2. Setpoint Source Selection
3. Preparing the VSC 2000 for PID control
4. Tuning
5. PID Tuning Summary:

**1. Control Wiring**

**WARNING! All wiring and input/output setup must be done while the VSC 2000 is disconnected from the power supply. Refer to the Control Wiring Diagram for details.**

- 1.1 Connect the process variable signal to Analog Input IN 2.
- 1.2 If required connect Setpoint Variable signal or Feed Forward signal to Analog Input IN 1.
- 1.3 Connect any metering device to an Analog Output as required.
- 1.4 Ensure input signal voltage levels are compatible with input specifications. Refer to the **PID Controller Wiring Diagram** above for examples.

**2. Setpoint Source Selection**

The Setpoint source is selected via the control terminal speed reference selection (terminals 45, 46 and 47) for an external signal input, or can be the Speed Pot setting on the CCS, enabled using the 'CCS in Auto' feature - see the **VSC 2000 User's Manual**.

**3. Preparing the VSC 2000 for PID control**

- 3.1 After initial Power-On enter any settings as described by the **VSC 2000 Installation Manual** Quick Setup procedure.
- 3.2 Set the desired Maximum motor frequency at which the process may be safely driven.
- 3.3 Set span and zero values by setting the Minimum and Maximum values for each Analog Input in use.
- 3.4 Set span and zero values by setting the Minimum and Maximum values for each Analog Output in use.
- 3.5 Find the PID controller and enter the following:

**Note: Ensure the VSC 2000 is stopped and in Manual mode.**

**Note: Ensure the VSC 2000 is stopped and in Manual mode.**

**Enable the PID control .....(Defaults)**

- Select PID PARAMETERS and set PB (%) .....300%
- Set Ti (sec/r) ..... 2.00 sec/r
- Set I+ CLAMP % .....100%
- Set I- CLAMP % ..... -100%
- Set Td (sec) .....0.00 sec
- Set the INTEGRATOR PRESET .....0%
- Set OUTPUT+ CLAMP % .....100%
- Set OUTPUT- CLAMP % .....0%
- Select a FEED FORWARD VARIABLE reference .....ZERO
- Enable / Disable EXTERNAL OPEN/CLOSE as required..... Disabled
- Enable / Disable OUTPUT INVERSION ..... Disabled

**4. Tuning**

**CAUTION:** The following steps are applicable in most cases, however in some cases running the controller system without defined limits must be done with caution in case excessive speeds result in hazardous conditions or damage.

- 4.1 With the drive in MANual mode (open loop) run the system at a known operating Setpoint and verify that the Process Variable (PV) transducer feedback signal is at the correct level for this operating Setpoint. For example if you set 50% speed, the PV signal from the transducer should represent 50% e.g. 5 volts for a 0 to 10 volt signal, or 12 mA for a 4 to 20 mA signal etc. If not you may need to adjust the Span & Zero on the transducer or use scaling resistors for the transducer signal. (Also use selections available for ANALOG INPUTS such as Minimum, Maximum and Signal Condition to setup INPUT 2.)
- 4.2 If possible, operate the system at the maximum (safe) operating point and verify that the Process Variable signal is now at the expected level for this operating point.
- 4.3 Switch off the integrator by setting **Ti (sec/r)** to zero.
- 4.4 Close the control loop by operating the system in AUTO mode (closed loop) and observe the system behaviour (e.g. Process Variable signal). If the system is unstable increase the **PB (%)** to obtain stable system operation.

In general, increasing the **PB (%)** will stabilize the system. Decreasing the **PB (%)** will produce a faster response but may also de-stabilize system operation.

- 4.5 If the system response oscillates momentarily, the system is under damped. An increase of the derivative time value **Td (sec)** can improve damping. However, excessive **Td** may cause instability.
- 4.6 Allow the system to settle at a known operating Setpoint. If the Process Variable does not equal the Setpoint then the system has a steady state error. To remove the steady state error (i.e. Process Variable equal to the Setpoint) adjust the **Ti (sec/r)** value. Use a large value initially. Reducing the **Ti** value will eliminate steady state error more rapidly.
- 4.7 Minor adjustments to **PB, Ti** and **Td** may be performed to achieve the desired loop response. Use the summary table below for general remedies to common problems.
- 4.8 Change the **Display Units** in the Complete Setup menu from Hz to that of your selected process variable.
- 4.9 Set the **Display Scale** parameter in the Complete Setup menu as required.

The PID Controller Tuning is now completed. See Summary Table below.

**5. PID Tuning Summary:**

Problem	PID Tuning Adjustment
<b>In Open Loop:</b> Process Variable does not match desired operating Setpoint	Check transducer output signal Span and Zero or use scaling resistors
<b>In Closed Loop:</b> System is unstable	Increase Proportional Band <b>PB (%)</b> or decrease Derivative Time <b>Td</b>
System responds too slowly	Decrease <b>PB (%)</b>
System oscillates momentarily	Increase Proportional Band <b>PB (%)</b> or decrease Derivative Time <b>Td</b>
Process Variable does not equal desired operating Setpoint	Use or Increase the Integral Time <b>Ti</b>

## Definition of PID Settings

### PB (%): Proportional Band

The Proportional Band is defined as the percentage of input signal required to produce 100% output signal. This value adjusts the 'loop-gain' of the system. In general a larger value will result in a smaller loop-gain. If systems become unstable and oscillates, increasing the PB % will dampen the oscillations.

### Ti (sec/r): Integrator Time (seconds/repeat)

The Integral Time (or reset time) is the period of time the integrator output takes to repeat the input signal level i.e. seconds/repeat or **sec/r**. For example, if  $T_i = 5 \text{ sec/r}$  and a 10 Hz step (from 0 Hz) is applied to the integrator input, the output will equal (or 'repeat') the input of 10Hz, 5 seconds later (this example assumes 100% proportional band).

The action of the integrator within the PID is to accumulate the error signal fed into it. If the error signal is positive, the integrator output will rise and if the error signal is negative, the integrator output will fall. In PID closed loop control, the action of the integrator drives the process to maintain zero steady state error.

In some cases driving the process to reach zero steady state error may be hazardous to the process or operators, and some limit must be set so that the process is driven safely. These limits are defined by '+ CLAMP %' and '- CLAMP %'.

### Td (sec): Derivative Time

The derivative control action is used to predict the future magnitude of the error signal. The derivative time  $T_d$ , specifies how far into the future (in seconds) to predict. For example suppose the error signal is a constant ramp of 10 Hz/sec starting from 0 Hz, and  $T_d = 0.5$  seconds. At 2 seconds the error is 20 Hz and the output of the derivative path is  $10 \text{ Hz/sec} \times 0.5 \text{ sec} = 5 \text{ Hz}$ . The result is summed with the error to yield 25 Hz which is the predicted error signal after 2.5 seconds.

### Integrator Preset:

When the PID controller is Enabled under closed-loop operation, and when the VSC 2000 is not running, the integrator is pre-set to the value entered as the INTEGRATOR PRESET.

### I+ Clamp %: Positive Integrator Clamp

The I+ CLAMP % specifies the upper clamp value for the integrator output. If the integrator output reaches this clamp value, the anti-windup mechanism activates and integrator is held at this level until the error changes polarity. If the error signal becomes negative the integrator output will begin to fall.

### I- Clamp %: Negative Integrator Clamp

The I- CLAMP % specifies the lower clamp value for the integrator output. If the integrator output reaches this clamp value, the anti-windup mechanism activates and integrator is held at this level until the error changes polarity. If the error signal becomes positive the integrator output will begin to rise.

### Output+ Clamp %: PID Output Positive Clamp

The OUTPUT+ CLAMP % sets the upper clamp value for the PID output. Should the output signal reach this clamp value, the anti-windup mechanism activates, integration will stop and the output is held at this level.

Note: The VSC 2000 will validate the number(s) entered for CLAMP % value and will not accept invalid entries!

### Setpoint:

The Setpoint input signal is the value for the quantity you want to control at the system output. For example a process requires gas pressure in a chamber to be maintained at 100 kPa and so the Setpoint is set to 100 kPa (sv = 100 kPa).

The Setpoint source is selected via the control terminal speed reference selection (terminals 45, 46 and 47) for an external signal input, or can be the Speed Pot setting on the CCS, enabled using the 'CCS in Auto' feature - see the **VSC 2000 User's Manual**. The Setpoint Variable displayed on the CCS can be scaled and have units as desired by using the 'Display Scale' and 'Display Units' features in the 'Complete Setup' menu on the CCS.

### Process Variable:

The Process Variable is the output quantity of the process. For example chamber pressure. The sensing equipment measures this quantity and produces the feed back signal for control.

When the PID Controller is enabled, the process variable signal is measured from analog input IN 2. Analog input IN 2 can accommodate reverse acting signals as well as the minimum and maximum levels of the input. Refer to the **VSC 2000 User's Manual** for details of analogue input configuration. In some situations it may be necessary to perform analog scaling prior to connection to the VSC 2000. There are miniature board options available from Zener Electric for these situations.

### Feed FWD:

The Feed forward is primarily used to help linearize the system and is the value that allows the operating point of the system to be shifted, leaving the PID Controller to regulate about this operating point. For example in a web tension control system the feed forward input is used to set the operating speed and the PID Controller regulates the web tension at this speed. The set-point is a web tension value and the process variable is the web tension feedback signal.

### External OPEN loop/CLOSED loop control:

This menu item enables or disables the function of control terminal 83. When this menu item is enabled and the CCS AUTO button is pressed *AND* +24V is applied to Control terminal 83, the system will be running under Closed loop control. When the CCS MANUAL button is pressed *OR* +24V is removed from Control terminal 83 the system will be running under Open loop control.

When this menu item is disabled the Open loop/Closed loop function is performed by the CCS MANUAL and AUTO buttons respectively.

### Output Inversion

Effectively multiplies the PID output signal by -1, inverting the signal.

### Display Scaling and Units:

When the PID controller is enabled the CCS run screen displays the PROCESS VARIABLE (feedback signal) in large digits. The PROCESS VARIABLE is prefixed with the indicator 'pv' in small characters. Immediately below the PROCESS VARIABLE display is the SETPOINT VARIABLE display in smaller digits. The SETPOINT VARIABLE is prefixed with the indicator 'sv' in small characters. The CCS also displays this information graphically with the bar graph along the bottom of the CCS run display. The presence of the 'pv' prefix and 'sv' prefix indicate to the operator that the PID controller is enabled.

The units of the PROCESS VARIABLE and SETPOINT VARIABLE may be changed from the default of 'Hz' as described in the **VSC 2000 User's Manual**. Similarly the display scaling may be changed from the default to reflect the correct significance of the process variable. For example an appropriate scale factor is needed for a transducer whose output range represents 200% of the required full scale deflection of the PROCESS VARIABLE.

The required SPEED SCALE parameter is calculated as follows:

$$K_{disp} = \frac{100\%}{200\%} \times f_{max}$$

Where:  $K_{disp}$  - is the DISPLAY SCALE parameter,

$f_{max}$  - is the MAXIMUM FREQUENCY output of the VSC 2000.

If the display scaling has been altered as have the units, and the inverter output frequency is still required it may be displayed via the meter readouts display to the right of the SETUP touch key. Refer to the **VSC 2000 User's Manual** for details.

### Output Signals:

Additional analog and digital output signals are available to compliment the PID controller. Refer to the **VSC 2000 User's Manual** for details of analog and digital output assignments.

Extra signals available to the analogue outputs are:

- PID OUTPUT, PROCESS VARIABLE, PID I SIGNAL..

Extra signals are available for digital output of the VSC 2000 terminal strip. The signals are:

- PID I SATURATION asserted when the integrator saturates;
- PID OUTPUT SATURATION asserted when the controller output is greater or equal OUTPUT+ CLAMP % or less or equal OUTPUT- CLAMP %;
- PV OVER ALARM asserted when the PROCESS VARIABLE is greater than the PV OVER ALARM threshold;

PV UNDER ALARM asserted when the PROCESS VARIABLE is less than the PV UNDER ALARM threshold.

## VSC 2000 COMMUNICATIONS

### Introduction

This manual describes how to achieve remote computer control of the **VSC 2000** features and operations via a serial communications link.

The **VSC 2000** uses the **RS-485** physical layer interface standard. This allows up to 31 **VSC 2000** drives to be connected on a single communication cable. This connection is referred to as 'multi-point' or 'party line' wiring schemes.

General purpose computers with serial communication ports are mostly of the RS-232 physical layer interface type. In order to achieve communications to the **VSC 2000**, a RS-232 to RS-485 converter is required. An alternative is to install a RS-485 option card directly in your computer.

RS-232 is a 'single ended' (unbalanced) specification where signal transmission is done over a single cable conductor and the receiver compares each signal to circuit common. This arrangement makes RS-232 susceptible to transmission errors due to common mode interference. RS-232 permits two devices to be connected (point-to-point) and can achieve up to 20 kBit/sec over a cable length of 15 meters. Longer distances are possible, but at lower bit rates.

RS-485 is a 'differential' (balanced) specification where signal transmission is done over a pair of cable conductors (the signal and its logical complement). The receiver compares the voltage between the pair of conductors, so any common mode interference is cancelled. RS-485 permits two or more devices to be connected in a multi-drop or parallel configuration and can achieve 100 kBit/sec over a cable length of 1200 meters.

An alternative to using wire is to use a fibre optic transceiver to convert standard RS-232 electrical signals to optical signals. This will provide far greater noise immunity for longer distances as well as total electrical isolation often important for equipment connected over long distances in industrial environments, or for applications such long conveyor belts exposed to lightning strikes and varying ground potentials.

Although RS-232 and RS-485 are standard protocols, not all converters are alike. You must use an isolated converter, and we recommend you try and use those which are known by **Zener** to work well. We currently support / have most with experience the JAMECO isolated RS232/485 converter (Jameco part no. 122956).

### Interface Specifications

Computer Interface	2 wire RS-485 (multi point) 4 wire RS-485 (point to point or multi point)
Bit rates	19200 bits/second 9600 bits/second 4800 bits/second 2400 bits/second
Data formats	no parity, 8 data bits, 1 stop bit even parity, 7 data bits, 1 stop bit odd parity, 7 data bits, 1 stop bit
Interface Terminals (isolated circuits)	1 (TX+) transmitter data positive 2 (TX-) transmitter data negative 3 (RX+) receiver data positive 4 (RX-) receiver data negative 5 (USP COM) signal common 6 (SCN) screen (chassis earth)

### Installation - Wiring

Figure 1 below contains the four network configurations supported. In each case some wiring installation precautions will help minimise the risk of network failure. These precautions include:

- Use shielded communications cable.
- It is recommended that the circuit commons be connected in addition to communication conductors.
- Each length of cable should have its shield connected to ground at one end only. The shield connection should be made as close as possible to the earthing conductor.
- Avoid laying communication cables adjacent to power cabling and wiring. If not possible utilize the best separation of communication cabling and power cabling.
- If communication cables must cross power cables, they should do so at right angles to each other.

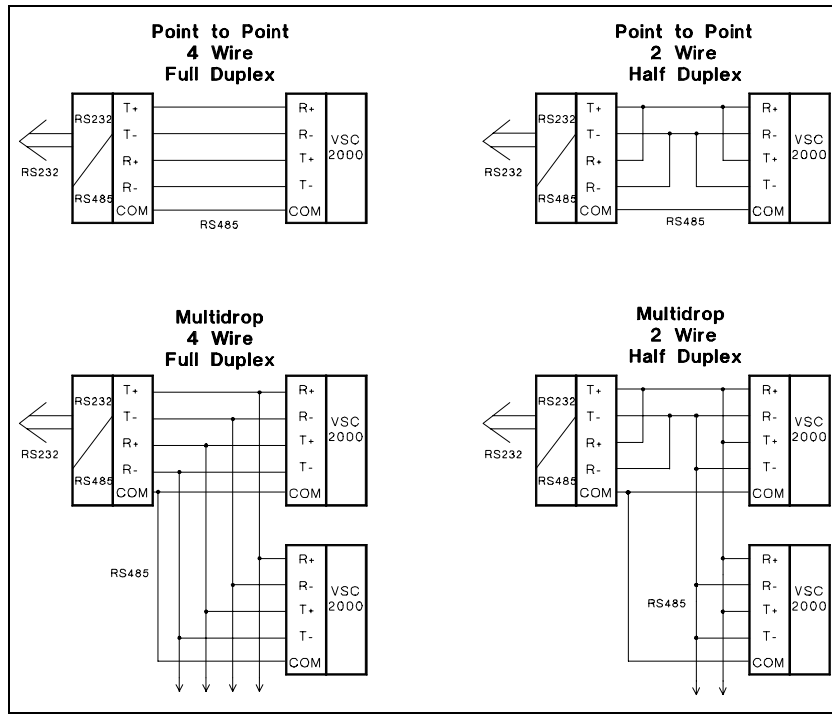

**Figure 1:** Wiring configuration for 2 and 4 wire RS-485. Use sheilded cable in all cases to minimise susceptibility to electrical noise.

Termination of the communication cabling may be required for some applications. Figure 2 shows how SW3 on the VSC2000 control board governs the cabling terminations and shows the default switch configuration for 4 wire, full duplex connection to a computer with an RS232 to RS485 isolating converter.

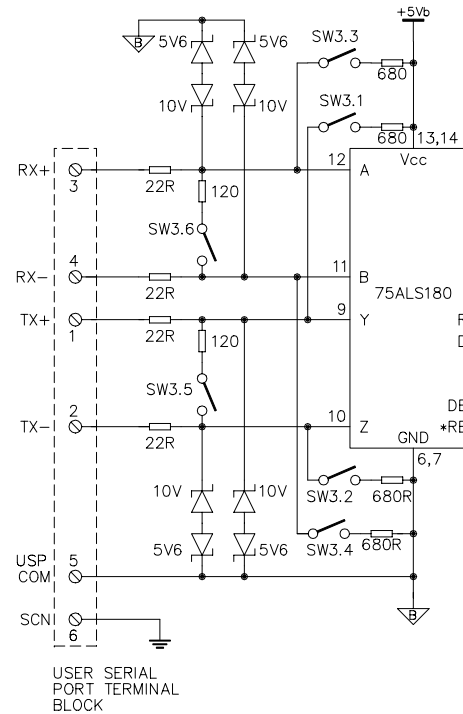

**Figure 2:** User Serial Port configuration showing location of DIP Switches used to configure the port.

### Communications Setup

Communication settings may be changed through the setup menu (see the User manual for details). The settings are:

Choices	Default	Choices
DRIVE ID NUMBER	0	0..31
BIT RATE	9600	19200,9600,4800,2400
DATA FORMAT	n81	n81 (no parity,8 data bits, 1 stop bit), e71 (even parity,7 data bits, 1 stop bit), o71 (odd parity,7 data bits, 1 stop bit)
2/4 WIRE	4 WIRE	2 WIRE, 4 WIRE

## Communication Commands

**Commands** Note: r - read only, w - write only, r/w - read + write

*Character*      *Description*

<b>@</b>	<b>-Select drive command</b>	<b>r/w</b>
----------	------------------------------	------------

<b>Command</b>	<b>Response</b>	
@<address><cr>	<cr><lf>	r

Address or select a drive for communication. Each drive connected will compare the <address> with it's own and if matched responds with <cr><lf>. If address is not matched, the command is ignored and the drive is not selected. Any previously addressed drive is no longer addressed. There is no response if no drive matches <address> with it's own.

<b>Command</b>	<b>Response</b>	
@<cr>	< address>.<select ><cr><lf>	r

Issue of this command will cause the currently addressed drive to respond with it's <address> and it's <select> status. The <select> is either '0' meaning it will not respond to a multi-cast command or '1' meaning it will respond to a multi-cast command.

<b>Command</b>	<b>Response</b>	
@<address>.<select><cr>	<cr><lf>	w

Selects a drive for communication and enables or disables the selective address-all feature. If a drive matches <address> with it's own and <select> is '1' then the selective address-all feature is enabled. This means that the selected drive will process a multi-cast command. If <select> is '0' the feature is disabled and multi-cast commands are ignored.

*Character*      *Description*

<b>A</b>	<b>-Acceleration time command</b>	<b>r/w</b>
----------	-----------------------------------	------------

<b>Command</b>	<b>Response</b>	
A<cr>	< acceleration time ><cr><lf>	r

Prompt the currently selected drive to output it's acceleration time value.

<b>Command</b>	<b>Response</b>	
A<acceleration time><cr>	<cr><lf>	w

Specifies the acceleration time in seconds to the selected drive. The acceleration time is the time it takes a drive output to reach base speed from zero (e.g.: 0 to 50Hz). The range for <acceleration time> is from 0.5 to 600 seconds.

*Character*      *Description*

<b>B</b>	<b>-Automatic Boost setting</b>	<b>r/w</b>
----------	---------------------------------	------------

<b>Command</b>	<b>Response</b>	
B<cr>	<auto boost %><cr><lf>	r

Prompt the currently selected drive to output it's automatic boost percentage.

<b>Command</b>	<b>Response</b>	
B<auto boost %><cr>	<cr><lf>	w

Specifies the automatic boost percentage to the selected drive. The range for <auto boost %> is from 0 to 100 %.

*Character*      *Description*

<b>C</b>	<b>-Output current magnitude</b>	<b>r</b>
----------	----------------------------------	----------

<b>Command</b>	<b>Response</b>	
C<cr>	<current magnitude><cr><lf>	r

Prompts the currently selected drive to return it's output current magnitude.

*Character*      *Description*

<b>D</b>	<b>-Deceleration time command</b>	<b>r/w</b>
----------	-----------------------------------	------------

<b>Command</b>	<b>Response</b>	
D<cr>	<deceleration time ><cr><lf>	r

Prompts the currently selected drive to return it's deceleration time value.

<b>Command</b>	<b>Response</b>	
D<deceleration time><cr>	<cr><lf>	w

Specifies the deceleration time in seconds to the selected drive. The deceleration time is the time it takes a drive output to reach zero from base speed (e.g.: 50 to 0Hz). The range for <deceleration time> is from 0.5 to 600 seconds.

*Character*      *Description*

<b>F</b>	<b>-Drive output frequency command</b>	<b>r/w</b>
----------	--	------------

<b>Command</b>	<b>Response</b>	
F<cr>	<output frequency><cr><lf>	r

Prompts the selected drive to return it's output frequency. The <output frequency> is prefixed with either '+' or '-' to indicate forward or reverse respectively.

**Command**  
F<output frequency><cr>  
**Response**  
<cr><lf> w

Sets the <output frequency> reference. The range for the <output frequency> is 0.0 to 200.0Hz. Note: For the VSC 2000 to respond to this command, the Control Wiring at the Control Terminals must be configured to select Preset Speed 1 (see **VSC 2000 Installation Manual**). Note: Use the R command for direction control.

**Command**  
F<preset #>:<cr>  
**Response**  
<output frequency><cr><lf> r

The selected drive returns it's value for the Preset Speed specified by <preset#> where <preset#> is a digit from 1 to 6.

**Command**  
F<preset#>:<output frequency><cr>  
**Response**  
<cr><lf> w

Sets the nominated Preset Speed to the value specified by <output frequency>.

**Command**  
Fx:<cr>  
**Response**  
<max frequency><cr><lf> r

Retrieves the maximum frequency setting of the selected drive.

**Command**  
Fn:<cr>  
**Response**  
<min frequency><cr><lf> r

Retrieves the minimum frequency setting of the selected drive.

**Command**  
Fx:<max frequency><cr>  
**Response**  
<cr><lf> w

Sets the maximum frequency setting of the selected drive. The range for the maximum is 5 to 200 Hz.

**Command**  
Fn:<min frequency><cr>  
**Response**  
<cr><lf> w

Sets the minimum frequency setting of the selected drive. The range for the minimum is 0 to the maximum frequency minus 5 Hz. Note: negative values are not accepted. You must use the **R** command for direction control.

Character	Description	
<b>H</b>	<b>-I<sup>2</sup>t command</b>	r/w

**Command**  
H<cr>  
**Response**  
<status>,<I<sup>2</sup>t value%><cr><lf> r

The selected drive returns it's I<sup>2</sup>t configuration.

**Command**  
H<status>,<I<sup>2</sup>t value%><cr>  
**Response**  
<cr><lf> w

Configure the I<sup>2</sup>t setting in the selected drive(s).

Where:  
 <status> '0' to disable I<sup>2</sup>t, '1' to enable I<sup>2</sup>t  
 <I<sup>2</sup>t value%> I<sup>2</sup>t trip setting, 50 to 150%

**Command**  
H.1<cr>  
**Response**  
<I<sup>2</sup>t used%><cr><lf> r

The selected drive returns it's 'used thermal capacity' (similar to motor temperature). When <I<sup>2</sup>t used%> reaches the I<sup>2</sup>t setting <I<sup>2</sup>t value>, the drive will trip.

Character	Description	
<b>I</b>	<b>-Identify command</b>	r

**Command**  
I<cr>  
**Response**  
VSC-2<model><cr><lf>  
CCS <CCS version><cr><lf>  
CTL <CTL version><cr><lf>  
PWM <PWM version><cr><lf> r

The selected drive returns it's model identification as well as it's firmware version and revision details for each of the three EPROMs. The returned information is identical to the information that is displayed on the front panel CCS touch screen every time a **VSC 2000** is switched on.

Character	Description	
<b>J</b>	<b>-Jog command</b>	r/w

**Command**  
J<cr>  
**Response**  
PRE:<speed><cr><lf> r  
OR  
IN2<cr><lf> r

Retrieves the jog setting from the selected drive. Two responses are possible. 1/ Returns PRE:<speed>, the speed in Hz for the JOG PRESET. 2/ Returns 'IN2' for the external speed reference on ANALOG INPUT 2. No speed value is returned for IN2 since this is an external reference.

<b>Command</b>	<b>Response</b>	
JPRE:<speed><cr>	<cr><lf>	w
Sets JOG PRESET and the JOG PRESET speed in the selected drive(s) to <speed>.		

<b>Command</b>	<b>Response</b>	
JIN2<cr>	<cr><lf>	w
Sets the JOG speed reference in the selected drive(s) to ANALOG INPUT 2.		

<i>Character</i>	<i>Description</i>	
------------------	--------------------	--

<b>L</b>	<b>-Current limit command</b>	<b>r/w</b>
----------	-------------------------------	------------

<b>Command</b>	<b>Response</b>	
L<cr>	<current limit %><cr><lf>	r
Selected drive returns the current limit as a percentage of the drive's continuous rating.		

<b>Command</b>	<b>Response</b>	
L<current limit %>	<cr><lf>	w
Sets the selected drive's current limit percentage to the value <current limit %>. The range of values for <current limit %> is from 36% to 110%.		

<i>Character</i>	<i>Description</i>	
------------------	--------------------	--

<b>M</b>	<b>-Motor command</b>	<b>r/w</b>
----------	-----------------------	------------

<b>Command</b>	<b>Response</b>	
MV<cr>	<motor voltage><cr><lf>	r
Retrieves the motor voltage (Volts) setting of the selected drive.		

<b>Command</b>	<b>Response</b>	
MC<cr>	<motor current><cr><lf>	r
Retrieves the motor current (Amps) setting of the selected drive.		

<b>Command</b>	<b>Response</b>	
MF<cr>	<motor frequency><cr><lf>	r
Retrieves the motor frequency (Hz) setting of the selected drive.		

<b>Command</b>	<b>Response</b>	
MS<cr>	<motor speed><cr><lf>	r
Retrieves the motor speed (rpm) setting of the selected drive.		

<b>Command</b>	<b>Response</b>	
MV<motor voltage><cr>	<cr><lf>	w
Sets the motor voltage (Volts) in the selected drive(s).		

<b>Command</b>	<b>Response</b>	
MF<motor frequency><cr>	<cr><lf>	w
Sets the motor frequency (Hz) in the selected drive(s).		

<b>Command</b>	<b>Response</b>	
MS<motor speed><cr>	<cr><lf>	w
Sets the motor speed (rpm) in the selected drive(s).		

<i>Character</i>	<i>Description</i>	
------------------	--------------------	--

<b>P</b>	<b>-PID command</b>	<b>r/w</b>
----------	---------------------	------------

<b>Command</b>	<b>Response</b>	
P<cr>	<status><extO/C><cr><lf>	r

Retrieves two binary status digits from the selected drive,  
Where:

<status>	'0', PID is disabled, '1', PID is enabled
<extO/C>	'0', external Open/Close feature is enabled '1', external Open/Close feature is disabled.

<b>Command</b>	<b>Response</b>	
P:<status><extO/C><cr>	<cr><lf>	w
Sets the PID status and external Open/Close status in the selected drive(s).		

<b>Command</b>	<b>Response</b>	
PT<cr>	<cr><lf>	w
Configures the PID controller for tacho feedback operation.		

<b>Command</b>	<b>Response</b>	
P<parameter><cr>	<value><cr><lf>	r
Retrieves a parameter value from the selected drive. The table to follow has details for specifying the <parameter> field.		

<b>Command</b>	<b>Response</b>	
P<parameter>:<value><cr>	<cr><lf>	w
Command sets the PID parameter in the selected drive(s).		

Parameter name	<parameter>	<value>	Parameter name	<parameter>	<value>
PB %	0	0 to 999.9%	I- clamp %	5	+/- 100%
Ti (sec/r)	1	0.05 to 19.99 (sec/r)	Output + clamp%	6	+/- 100%
Td (sec)	2	0.25 to 5.00 sec	Output - clamp%	7	+/- 100%
Integrator Preset	3	+/- 100%	Feed fwd	8	(see below)
I+ clamp %	4	+/- 100%			

The following are available Feed Fwd references

Reference	<value>	Name	<value>
ZERO	0	Preset 3	5
IN 1	1	Preset 4	6
CCS Speed pot	2	Preset 5	7
Preset 1	3	Preset 6	8
Preset 2	4	x	x

Character Description

<b>R</b>	<b>-Remote terminal control command</b>	<b>r/w</b>
----------	---	------------

All but one of the input terminals to the **VSC 2000** may be overridden by the R command. The exception is terminal 40 (Enable). The R command permits a mixture of remote and local terminal control. Remote control of terminals is enabled by sending a *mask* value to the selected drive(s) via the **Rm** command.

The *mask* value comprises twelve binary digits (0's and 1's) with the left most digit representing terminal 40, and the right most digit, terminal 83. For example 001100000000, allows terminals 42 and 43 to be remotely set. will set the terminal on (as if connected to +24V) and '0' will set the terminal off (as if left open).

Once terminals are set for remote control a *state* is sent via a **Rs** command. A '1' will set terminal on (as if connected to +24V) and '0' will set the terminal off (as if left open).

**Note:** To disable the CCS touch screen from manual intervention see Disable the CCS Touch Screen page 2.

**Command** **Response**  
**Rm**<cr> <mask><cr><lf> r  
 The selected drive will return twelve binary digits of the mask value in <mask>. A '1' indicates that the corresponding terminal is set to remote.

**Command** **Response**  
**Rs**<cr> <state><cr><lf> r  
 The selected drive will return twelve binary digits in <state> representing the state of the terminals (ordered left to right for terminals 40-47,80-83). A '1' indicates that the corresponding terminal is set 'ON'.

Once terminals are set for remote control a *state* is sent via a **Rs** command. A '1'

**Command** **Response**  
**Rm**<mask><cr> <cr><lf> w  
 Sets the mask value in the selected drive(s) as specified by the twelve binary digits in <mask>. A '1' indicates that the corresponding terminal is set for remote.

**Command** **Response**  
**Rs**<terminal><state><cr> <cr><lf> w  
 Sets the <terminal> to the value specified by <state>. The value of <state> is either a '0' or '1' where a '1' indicates that the corresponding terminal is set 'on'.

<terminal>	Terminal designation	<terminal>	Terminal designation
B	terminal 41	H	terminal 47
C	terminal 42	J	terminal 80
D	terminal 43	K	terminal 81
E	terminal 44	L	terminal 82
F	terminal 45	M	terminal 83
G	terminal 46		

Character Description

<b>S</b>	<b>-Status command</b>	<b>r</b>
----------	------------------------	----------

Retrieves the running status of the selected drive. The returned status comprises 9 hexadecimal digits. Each hexadecimal digit comprises 4 status bits. The following tables can be used to decode the drive status digits.

**Command** **Response**  
**S**<cr> <drive status><cr><lf> r

The selected drive will return it's 9 hexadecimal <drive status> digits.

Status digit	Bit3 set to '1'	Bit2 set to '1'	Bit1 set to '1'	Bit0 set to '1'
1st	Over current trip	Earth fault trip	Phase fail trip	Power fail trip
2nd		Over voltage trip	I <sup>2</sup> t trip	Under voltage trip
3rd	DC braking indicator		Bus relay energized	Reverse indicator
4th	Bus charging status	Power fail status	Voltage limit indicator	Current limit indicator
5th		PID output clamping	PID integrator clamping	Ambient over Temp. trip
6th	Heatsink over Temp. trip	Output phase imbalance trip		Bus relay failure trip
7th	data card corrupted	Incorrect current resistor	Incorrect Voltage resistor	Invalid drive type
8th	Current resistor open circuit	Current resistor short circuit	Voltage resistor open circuit	Voltage resistor short circuit
9th	Run status	Reverse status	Manual control status	Motor direction status
10th	Zero speed	Under speed	Over speed	At speed
11th				Real time clock corrupted
12th	No clock found	Data card corrupted	Data card not programmed	No data card found
13th				
14th	Start timer status	Drive enabled	Thermistor short circuit	Thermistor trip
15th				
16th				

Hex digit	Bit pattern 3-2-1-0	Hex digit	Bit pattern 3-2-1-0	Hex digit	Bit pattern 3-2-1-0
0	0000	6	0110	C	1100
1	0001	7	0111	D	1101
2	0010	8	1000	E	1110
3	0011	9	1001	F	1111
4	0100	A	1010	x	x
5	0101	B	1011	x	x

Character Description

<b>T</b>	<b>-Test command</b>	<b>r</b>
----------	----------------------	----------

Command Response

T<variable ID><cr> <value><cr><lf> r

Retrieves an internal variable from the selected drive. The Table below lists the internal variables and the associated <variable ID> assignments.

Internal variable	<Variable ID>	Internal variable	<Variable ID>
T0 :(ambient)	0	T6:	6
T1:	1	T7:	7
T2:	2	Bus volts	8
T3:	3	Drive output power	9
T4:	4	Operating carrier	10
T5:	5	% load	11

Character Description

<b>a</b>	<b>-Auto restart command</b>	<b>r/w</b>
----------	------------------------------	------------

Command Response

a<cr> <status>,<resetT>,<restarts><cr><lf> r

Retrieves the auto restart configuration from the selected drive.

Command Response

a:<status>,<resetT>,<restarts><cr><lf> w

Sets the auto restart configuration in the selected drive(s), where:

- <status> '0' for disabled, '1' for enabled
- <resetT> The reset time in 0.1 seconds, range is 0.1 to 20 minutes (60 to 12000 ie. 1/10 seconds).
- <restarts> The number of restarts permitted (2 to 15).





**Command**                      **Response**  
**f**<feature><cr>                      <status><cr><lf>                      r

Retrieves the <status> of the <feature> in the selected drive. Refer to the following table for details on features and their settings.

**Command**                      **Response**  
**f**<feature>:<status><cr>                      <cr><lf>                      w

Sets the <status> of the <feature> in the selected drive(s).

Character	Description	
<b>g</b>	<b>-Hours_run log command</b>	<b>r</b>

**Command**                      **Response**  
**g**<cr>                      <hours\_run><cr><lf>                      r

Retrieves the number of hours that the drive has been running the motor (as indicated by the status of the Run Relay) since the log was reset.

Character	Description	
<b>h</b>	<b>-Trip log command</b>	<b>r</b>

**Command**                      **Response**  
**h**<number><cr>                      <status>,<time\_stamp>,<freq>,<temp><cr><lf>                      r

Retrieves a trip log record.

Where:

- <number>                      is the fault number (1 to 10 records, 1 is the most recent trip).
- <Status>                      is the sixteen character status as defined by the S command
- <time\_stamp>                      If the clock is fitted the date and time is retrieved. Otherwise the hours run value is recorded
- <freq>                      is the running frequency prior to trip
- <temp>                      Is the hottest temperature of the drive at the time of trip

Character	Description	
<b>i</b>	<b>-Analog input command</b>	<b>r/w</b>

**Command**                      **Response**  
**i**<number><cr>                      <type>,<min>,<max>,<cond><cr><lf>                      r

Retrieves the analog input configuration for the analog input specified by <number> ('1' or '2') from the selected drive.

Where:

- <type>                      '0' for 0 to 5 V configuration  
                               '1' for 0 to 10 V configuration  
                               '2' for 0 to 20mA configuration  
                               '3' for 4 to 20mA configuration
- <min>                      is the minimum input value. 0...1023 represents 0...100% of the selected configuration.
- <max>                      is the maximum input value. 0...1023 represents 0...100% of the selected configuration.
- <inv>                      '0' disable reverse acting, '1' enable reverse acting.
- <bip>                      '0' disable bipolar range, '1' enable bipolar range.

**Command**                      **Response**  
**i**<number>:<type>,<min>,<max>,<inv>,<bip><cr>                      <cr><lf>                      w

Sets the analog input configuration for the analog input 1 or 2 (specified by <number> '1' or '2') in the selected drive(s). Note: see the **VSC 2000 User's Manual**, Analog Inputs for DIP switch settings to configure the analog input circuits which can only be set this way.

Character	Description	
<b>o</b>	<b>-Analog output command</b>	<b>r/w</b>

**Command**                      **Response**  
**o**<number><cr> <type>,<min>,<max>,<src><cr><lf>                      r

Retrieves the analog output configuration for the analog input specified by <number> ('1' or '2') from the selected drive. Each configuration represents minimum to maximum frequency,

Where:

- <type>                      '0' for 0 to 5 V configuration  
                               '1' for 0 to 10 V configuration  
                               '2' for 0 to 20mA configuration  
                               '3' for 4 to 20mA configuration
- <min>                      is the minimum input value (Hz).
- <max>                      is the maximum input value (Hz).
- <src>                      see table below:

<src>	Signal	<src>	Signal
'0'	speed	'3'	PID feedback
'1'	load	'4'	PID output
'2'	bipolar load	'5'	PID 'I' signal

**Command** *o*<number>:<type>,<min>,<max>,<src><cr> **Response** <cr><lf> *w*

Sets the analog input configuration for the analog input specified by <number> ('1' or '2') in the selected drive(s). Note: see the **VSC 2000 User's Manual**, Analog Inputs for DIP switch settings to configure the analog input circuits which can only be set this way.

*Character Description*

**p** **-Slip compensation command** *r/w*

**Command** *p*<cr> **Response** <slip comp%><cr><lf> *r*

Retrieves the slip compensation % from the selected drive.

**Command** *p*<slip comp%><cr> **Response** <cr><lf> *w*

Sets the slip compensation % in the selected drive(s). The range for <slip comp%> is 0 to 150%.

*Character Description*

**r** **-Ramp command** *r/w*

The **VSC 2000** has two ramp specifications Ramp1 and Ramp2, that control acceleration and deceleration times.

**Command** *r*<cr> **Response** <ramp number><cr><lf> *r*

Retrieves the active ramp from the selected drive.

**Command** *r*<function number><cr> **Response** <value><cr><lf> *r*

Retrieves the ramp function number <value>, where value is as defined in the following table.

**Command** *r*<function number>:<value><cr> **Response** <cr><lf> *w*

Sets the <value> for the ramp <function> selected. Note: Do not supply a <value> field when retrieving ramp values.

<function>	Function description
1	Set ramp 1 as the active ramp (no value returned)
2	Set ramp 2 as the active ramp (no value returned)
3	Set / get Ramp 1 acceleration time
4	Set / get Ramp 1 acceleration s-curve time
5	Set / get Ramp 1 deceleration time
6	Set / get Ramp 1 deceleration s-curve time
7	Set / get Ramp 2 acceleration time
8	Set / get Ramp 2 acceleration s-curve time
9	Set / get Ramp 2 deceleration time
0	Set / get Ramp 2 deceleration s-curve time

*Character Description*

**s** **-Skip speed command** *r/w*

The s command permits the control of the skip speeds. Each skip setting comprises 3 fields: the skip speed, the skip speed range and the status. The skip speed and skip speed range are in Hz and the status is '0' for skip setting disabled and '1' for skip setting enabled.

There are four skip settings defined within the **VSC 2000**. Therefore, the skip setting number needs to be specified when retrieving or sending skip settings.

**Command** *s*<number><cr> **Response** <speed>,<range>,<status><cr><lf> *r*

Retrieves the skip setting (specified by <number>) from the selected drive.

**Command** *s*<number>:<speed>,<range>,<status><cr> **Response** <cr><lf> *w*

Sets the skip setting (specified by <number>) in the selected drive(s).

Character	Description	
t	<b>-Date and time command</b>	r/w

**Command** **Response**  
t<cr> <date time><cr><lf> r  
Retrieves the date and time setting of the selected drive. The format for the <date time> response is, 'ccyy/mo/dd-hh:mn:ss',

Where:

- cc is the century (00 to 99)
- yy is the year (00 to 99)
- mo is the month of the year (01 to 12)
- dd is the day of the month (1 to 31)
- hh is the hour of the day (00 to 23)
- mn is the minute of the day (00 to 59)
- ss is the second of the minute (00 to 59).

**Command** **Response**  
t<date time><cr> <cr><lf> w  
Sets the date and time in the selected drive(s).

Character	Description	
u	<b>-Audible frequency command</b>	r/w

**Command** **Response**  
u<cr> <value><cr><lf> r

Retrieves the audible (carrier) frequency from the selected drive.

**Command** **Response**  
u<value><cr> <cr><lf> w

Sets the audible (carrier) frequency in the selected drive(s). See table below:

Audible frequency	<Value>	Audible frequency	<Value>
Automatic selection	0	10 kHz	5
2 kHz	1	12 kHz	6
4 kHz	2	14 kHz	7
6 kHz	3	16 kHz	8
8 kHz	4		

Character	Description	
	<b>Data Card read command</b>	r/w

This command allows you to read the contents of the data card 8 bytes at a time, which can be saved to a file to retain your settings. The second command allows the contents to be restored without having to change the format of the data that you previously retrieved. The command returns '?' if the check sum does not match.

The <addr>address range is 0 to 800 Hex, and the <8databytes> and <check\_sum> values are also in Hexadecimal. The address method is offset based on blocks of 8 bytes eg. valid addresses are 000, 008, 010 etc. to read contiguous 8 byte blocks from 000. There are 256 blocks of 8 bytes total in the Data Card.

**Command** **Response**  
|<addr><cr> |<addr>:<8 databytes><check\_sum><cr><lf> r

This command reads an 8 byte datablock from the starting address <addr>.

**Command** **Response**  
|<addr>:<8 databytes><check\_sum><cr> <cr><lf> w

This command writes an 8 byte datablock from the starting address <addr>.

**Command compatibility with MSC drives**

The table below lists those commands that are compatible with the existing MSC family of drives available from ZENER ELECTRIC.

Command	Comment
@	Fully compatible
A	" "
B	" "
C	" "
D	" "
F	Command extensions available in VSC 2000
H	Data range is different
I	Data must be interpreted differently
L	Data range is different. Can R/W in VSC 2000
R	Data must be interpreted differently
S	Data must be interpreted differently

**Communications Command Summary**

Command	Page
@ -Select drive command r/w.....	33
A -Acceleration time command r/w.....	33
B -Automatic Boost setting r/w.....	33
C -Output current magnitude r.....	33
D -Deceleration time command r/w.....	33
F -Drive output frequency command r/w.....	33
H -I <sup>2</sup> t command r/w.....	34
I -Identify command r.....	34
J -Jog command r/w.....	34
L -Current limit command r/w.....	35
M -Motor command r/w.....	35
P -PID command r/w.....	35
R -Remote terminal control command r/w.....	36
S -Status command r.....	36
T -Test command r.....	37
a -Auto restart command r/w.....	37
b -Digital output command r/w.....	38
c -DC braking command r/w.....	38
d -Display units & scale r/w.....	38
e -Essential services command r/w.....	39
f -Feature command r/w.....	39
g -Hours_run log command r.....	40
h -Trip log command r.....	40
i -Analog input command r/w.....	40
o -Analog output command r/w.....	40
p -Slip compensation command r/w.....	41
r -Ramp command r/w.....	41
s -Skip speed command r/w.....	41
t -Date and time command r/w.....	42
u -Audible frequency command r/w.....	42
! Data Card read command r/w.....	42

**Australian  
Manufacturers**

DELIVERY ADDRESS  
366 Horsley Road  
MILPERRA  
NSW 2214  
AUSTRALIA

**ZENER ELECTRIC PTY LIMITED**

ACN 001 595 428

POSTAL ADDRESS  
P.O. Box 4462  
MILPERRA DC  
NSW 1891  
AUSTRALIA

Tel: +61-2 - 9795 3600  
Fax: +61-2 - 9795 3611  
Email: zener@zener.net

